



K-LINE INSULATORS LIMITED  
TORONTO, ONTARIO, CANADA

# Catalogue D-DS

## DISTRIBUTION SILICONE INSULATORS *Deadend / Suspension* *15 kV to 69 kV*

---

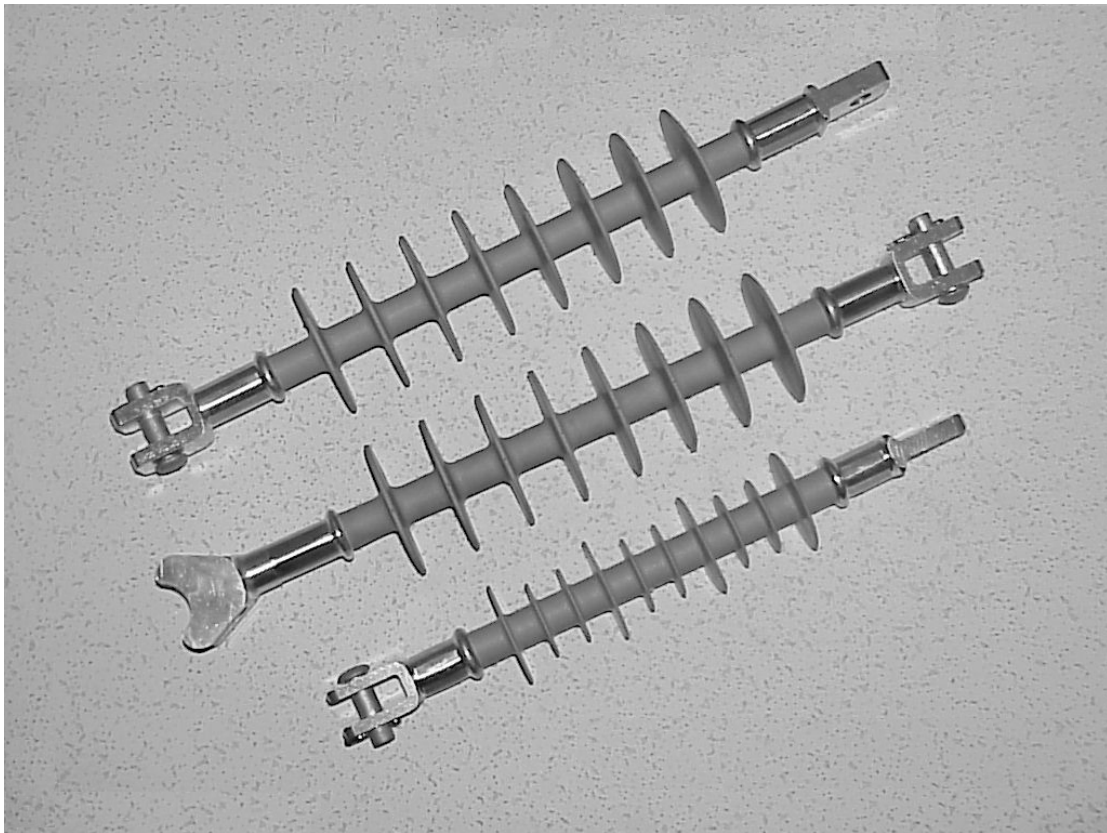

ISO9001  
SAI GLOBAL  
FILE No. 000117

# Distribution Silicone Insulators

## Deadend / Suspension

In general Overhead Distribution Lines tend to experience a large number of outages and interruptions due to insulation failures. These failures may be from surface contamination or wetting on line insulators that result in flashovers or pole fires.

Silicone Deadend/Suspension Insulators offer the ultimate solution in improved performance. Because of its hydrophobicity, this material inherently resists water filming thereby limiting leakage currents. Insulators with reduced leakage currents, even when contaminated, require less frequent washing. The savings in such maintenance costs are added benefits of using silicone insulators.

**K-LINE INSULATORS LIMITED (KLI)** silicone Distribution Deadend/Suspension Insulators are manufactured and tested in accordance with industry wide standards; CSA C411.5, ANSI C29.13, and IEC 61109.

**K-LINE INSULATORS LIMITED** is registered to ISO 9001 Quality Systems.

### PERFORMANCE BENEFITS

The performance benefits of **KLI** Distribution Deadend/Suspension Insulators are listed below.

- Improves Reliability (by mitigating interruptions and outages due to vandalism, pole fires, and flashovers in all types of environments)
- Eliminates or Reduces Maintenance (such as washing and trouble calls) and is compatible with existing installation
- Improves Power Quality (less RI and TVI)
- Energy Efficiency (lower losses due to lower leakage currents)
- Safety (light weight for handling and installation)
- Service Life (consistent performance over its service life)
- Life Cycle Cost (savings over ceramic insulators)

### APPLICATION

Distribution Deadend/Suspension Insulators are used on overhead lines operating at or below 69 kV. These insulators are used to support line conductors in suspension or deadend modes such as line terminations, angles, and tangents. These insulators can be used with bare or covered conductors.

### CORE ROD

The core rod of the insulator is made of a high quality, epoxy resin, ECR rod that has been specially formulated for electrical and mechanical applications. Each and every rod is subjected to an electrical test to ensure the integrity of the core rods used in the production of all insulators. KLI's rod is a higher torsion strength rating than standard requirements to ensure safer installation and line operation.

### HOUSING

The housing (includes sheath and sheds) of the insulator is one piece, high temperature vulcanized, injection molded silicone rubber that is chemically bonded to the core rod. This ensures that the interface between the rubber and rod is impenetrable against moisture ingress. **KLI** uses its own proprietary silicone rubber formula in the manufacture of its insulators. The formulation has silicone rubber as the base polymer material with additives to enhance its performance in wet and contaminated environments.

# DISTRIBUTION DEADEND/SUSPENSION INSULATORS

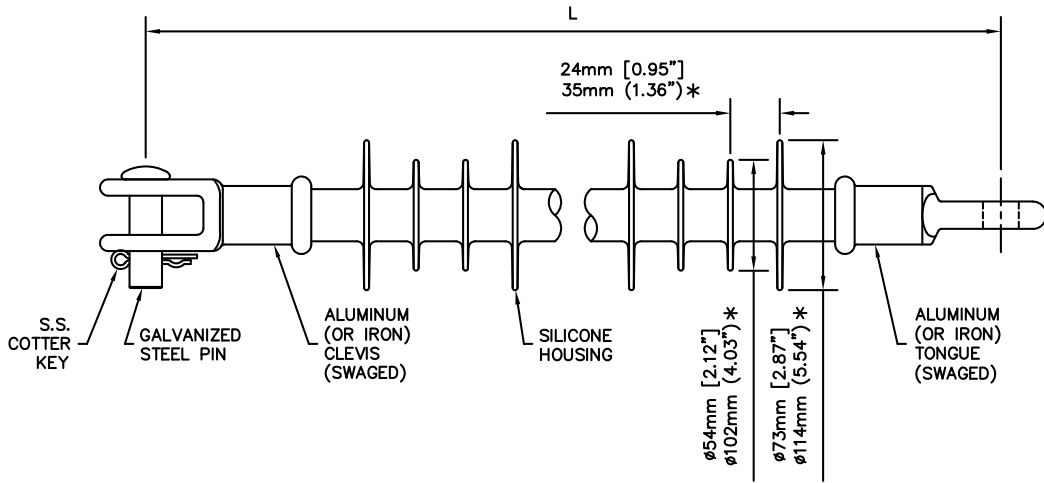

KL15ASCTM, KL28ASCTM, & KL69HC1T116 \*

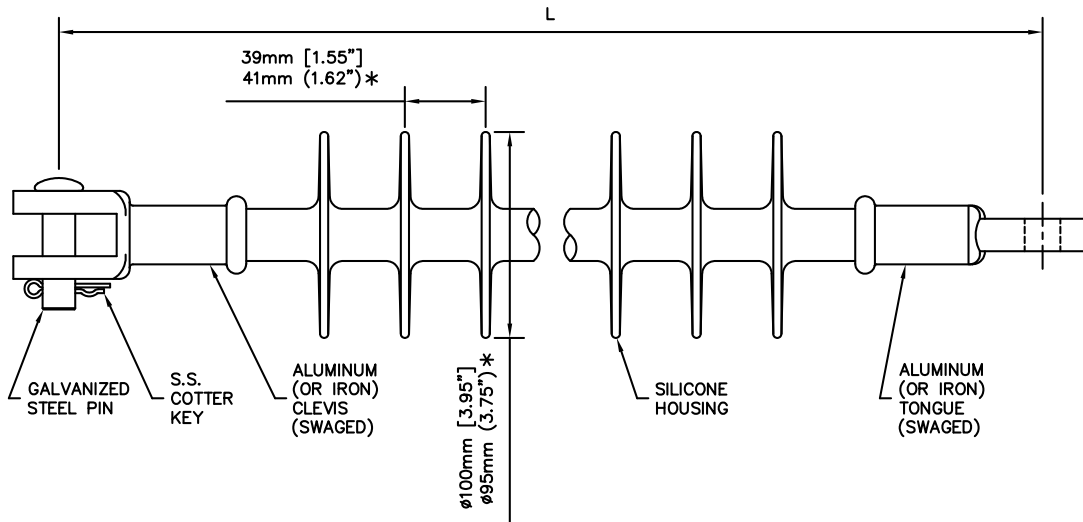

KL35SCTM\* & KL46SCT

## TECHNICAL DATA

SPECIFICATIONS	UNIT	CATALOGUE NUMBER**						
		KL15ASCTM	KL28ASCTM	KL35SCTM	KL46SCT	KL46SCTA	KL69HC1T116	
Voltage Class	kV	15	28	35	46	46	69	
CSA & ANSI Class	-	DS15	DS28	DS35	DS46	-	DS69	
Section Length "L"	mm (in)	322 (12.7)	433 (17.0)	486 (19.1)	574 (22.6)	646 (25.4)	733 (28.9)	
Dry Arcing Distance	mm (in)	193 (7.6)	290 (11.4)	348 (13.7)	419 (16.5)	490 (19.3)	627 (24.7)	
Leakage Distance	mm (in)	384 (15.1)	590 (23.2)	750 (29.5)	988 (38.9)	1059 (41.7)	1798 (70.8)	
Low-Frequency Flashover	Dry	kV	100	135	155	180	200	260
	Wet	kV	75	100	145	150	155	205
Positive Critical Impulse Flashover	kV	150	225	265	300	360	425	
Radio Influence Voltage (RIV) at 1 MHz	Test	kV	15	20	30	30	30	44
	Max.	µV	Below 1	Below 1	Below 3	Below 3	Below 3	1.2
Specified Mechanical Load (SML)	kN (lb)	70 (15,750)	70 (15,750)	70 (15,750)	90 (20,230)	90 (20,230)	90 (20,230)	
Torsional Load	N•m (ft•lb)	83 (62)	83 (62)	83 (62)	83 (62)	83 (62)	83 (62)	
Approx. Weight	kg (lb)	0.7 (1.5)	0.8 (1.8)	1.1 (2.5)	1.4 (3.0)	1.6 (3.5)	2.2 (4.8)	
Standard Packaging	-	21	21	14	12	12	6	

\*\* The catalogue numbers in the above table are for "CT" clevis-tongue fittings. For other combinations of end fittings, specified mechanical strengths or material, see End Fittings Section.

## END FITTINGS

There are six standard end fittings that are available on the Deadend/Suspension Insulators: Clevis, Tongue, Oval Eye, "Y" Clevis, Socket and Ball (See Below). The Clevis and Tongue fittings are made from high strength, corrosion resistant extruded aluminum or hot-dip galvanized iron or steel. While the socket, ball, thimble eye, oval eye, and "y" clevis fittings are made from hot-dip galvanized iron or steel. The end fittings are crimped on to the core rod to provide the mechanical performance. A watertight seal between the rubber and end fittings eliminates moisture ingress. This special silicone rubber to metal fittings sealing process provides total exclusion of moisture.

The end fittings of the Distribution Class Deadend/Suspension are rated for a specified mechanical strength, SML of 70 kN (15,750 lb) or 90 kN (20,230 lb).

The Clevis and Tongue end fittings are the two most common fittings used with additional adaptors and clamps. For other special end fittings please contact **KLI**.

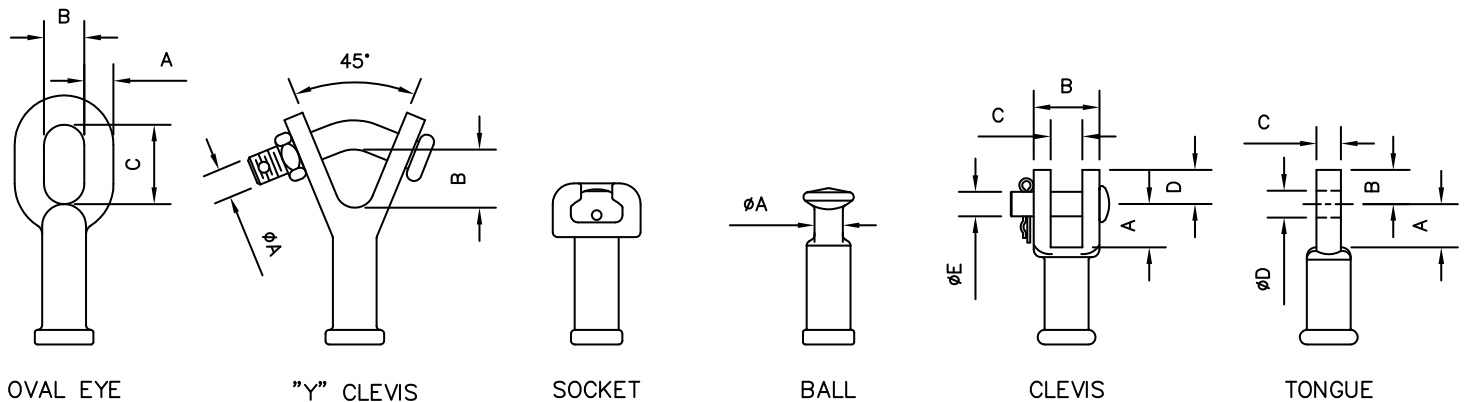

## END FITTING RATINGS AND DIMENSIONS

End Fitting	End Fitting Designation	Material	SML kN (lbs)	Class	Dimensions (in)				
					A	B	C	D	E
Oval Eye	E	Galvanized Iron	90 (20,230)	-	0.75	1.03	2.03	-	-
Y-Clevis	Y	Galvanized Iron	90 (20,230)	-	0.75	1.47	-	-	-
Socket	S	Galvanized Steel	90 (20,230)	ANSI 52-5	-	-	-	-	-
IEC Ball	B IEC	Galvanized Steel	90 (20,230)	IEC 16A	16 mm	-	-	-	-
ANSI Ball	B	Galvanized Steel	90 (20,230)	ANSI 52-5	0.72	-	-	-	-
Clevis	C_F	Galvanized Iron	70 (15,750)	-	1.03	1.36	0.71	0.81	0.63
	C	Aluminum	70 (15,750)	-	1.11	1.38	0.75	0.88	0.63
			90 (20,230)	-	1.11	1.69	0.81	0.87	0.63
Tongue	T_F	Galvanized Iron	70 (15,750)	-	1.05	0.88	0.50	0.70	-
	T	Aluminum	70 (15,750)	-	1.14	0.87	0.52	0.69	-
			90 (20,230)	-	1.11	0.87	0.62	0.69	-



### K-LINE INSULATORS LIMITED

50 Passmore Avenue, Toronto, Ontario, Canada M1V 4T1

• Tel.: (416) 292-2008 • E-Mail: [insulators@k-line.net](mailto:insulators@k-line.net) • Web Page: [www.k-line.net](http://www.k-line.net)



**K-LINE INSULATORS LIMITED**  
TORONTO, ONTARIO, CANADA

# Catalogue D-LP

## **DISTRIBUTION SILICONE INSULATORS**

### *Line Post*

### *15 kV to 69 kV*

---



ISO9001  
SAI GLOBAL  
FILE No. 000117

---

# Distribution Silicone Insulators Line Post

Insulator contamination is a common problem on overhead lines. The fundamental element for interruptions with contaminated insulators is moisture. Wet atmospheric conditions result in water filming on surfaces and causing leakage currents to develop. On wood structures, leakage currents can cause pole fires. On steel structures, leakage currents can develop into faults.

Silicone rubber formulations offer the ultimate solution in Line Post Insulator material. Due to its hydrophobicity, this material inherently resists water filming thereby limiting leakage currents. Silicone rubber insulators reduce leakage currents, even when contaminated and require less frequent washing. The savings in such maintenance costs are added benefits of using Silicone Rubber Insulators.

**K-LINE INSULATORS LIMITED (KLI)** silicone Distribution Line Post Insulators are manufactured and tested in accordance with industry wide standards, CSA C411.6, IEC 61952 and ANSI C29.18.

**K-LINE INSULATORS LIMITED** is registered to ISO 9001 Quality Systems.

## PERFORMANCE BENEFITS

The performance benefits of **KLI** Distribution Line Post Insulators are listed below.

- Improves Reliability (by mitigating interruptions and outages due to vandalism, pole fires, and flashovers in all types of environments)
- Eliminates or Reduces Maintenance (such as washing and trouble calls) and is compatible with existing installation
- Improves Power Quality (less RI and TVI)
- Energy Efficiency (lower losses due to lower leakage currents)
- Safety (light weight for handling and installation)
- Service Life (consistent performance over its service life)
- Life Cycle Cost (savings over ceramic insulators)

## APPLICATION

Distribution Silicone Line Post Insulators are used on overhead distribution lines operating at and below 69 kV. These insulators are commonly installed on metal, concrete or wooden structures to horizontally or vertically support the line conductor. Also, these insulators can be used to support high voltage conductor jumpers or leads.

## CORE ROD

The core rod of the insulator is made of a high quality, epoxy resin, E-Glass fiberglass rod that has been specially formulated for electrical and mechanical applications.

## HOUSING

The housing (includes sheath and sheds) of the insulator is one piece, high temperature vulcanized, injection molded silicone rubber that is chemically bonded to the core rod. This ensures that the interface between the rubber and rod is impenetrable against moisture ingress. **KLI** uses its own proprietary silicone rubber formula in the manufacture of its insulators. The formulation has silicone rubber as the base polymer material with additives to enhance its performance in wet and contaminated environments.

# END FITTINGS

## LINE END FITTING

The line end fitting of Line Post Insulators are available in four different configurations: Horizontal or Vertical Clamp-Top, Tie-Top, or K-CLAMP®.

End fittings on Line Post Insulators are made of corrosion resistant aluminum alloy or galvanized iron castings.

### SECTION LENGTH ADJUSTMENT

Line End Fitting	Line End Fitting Designation	Section Length
K-CLAMP®	K	See Technical Data sheet
Horizontal	H	L - 9 mm (0.4")
Vertical	V	L - 23 mm (0.9")
Tie-Top (F-neck)	TF	L - 33 mm (1.3")
Tie-Top (C-neck)	T	L - 53 mm (2.1")

### Clamp-Top

The conventional horizontal and vertical trunnion accommodates a standard Line Post Insulator, bolted conductor clamp. On the horizontal design the line end fitting has an additional eye for the attachment of other devices during installation or maintenance activities.

### Tie-Top

The tie-top is designed for tying a conductor to the neck of the insulator. It is available in two standard neck sizes: C or F-neck.

### K-CLAMP®

K-LINE introduced the original K-CLAMP® concept in the polymer Line Post live end fitting design. The uniqueness of this end fitting is a result of the many advantages it has over the traditional horizontal, vertical and tie-top configurations.

Some advantages of the K-CLAMP® include:

- 1) Excellent corrosion resistant aluminum casting
- 2) A long, smooth contoured conductor clamping zone
- 3) The clamp accommodates a full range of conductor sizes. 5.1mm (0.20") to 34.0mm (1.34")
- 4) A single captive live-line operable bolt
- 5) All parts are captive
- 6) Its overall length permits standard cover up hoods to effectively cover all insulator sheds
- 7) The design can be installed in either a horizontal or vertical configuration
- 8) Inventory reduction is accomplished because one insulator is used for both configurations and a separate clamp is not required
- 9) The price of the new insulator is cost comparative with the purchase of a standard trunnion post insulator and a separate clamp
- 10) Substantial labour cost savings in stringing, sagging and conductor clamping
- 11) Other savings related to shipping, stocking and maintenance

## BASE END FITTING

The standard base for Line Post Insulators is a round flat iron base with a threaded hole that accommodates a standard insulator stud or bolt. For other special bases contact **KLI**.

Hot-dip galvanizing to CSA G164 or ASTM A153 specifications provides corrosion protection of the base end fitting.

## LINE POST INSULATORS

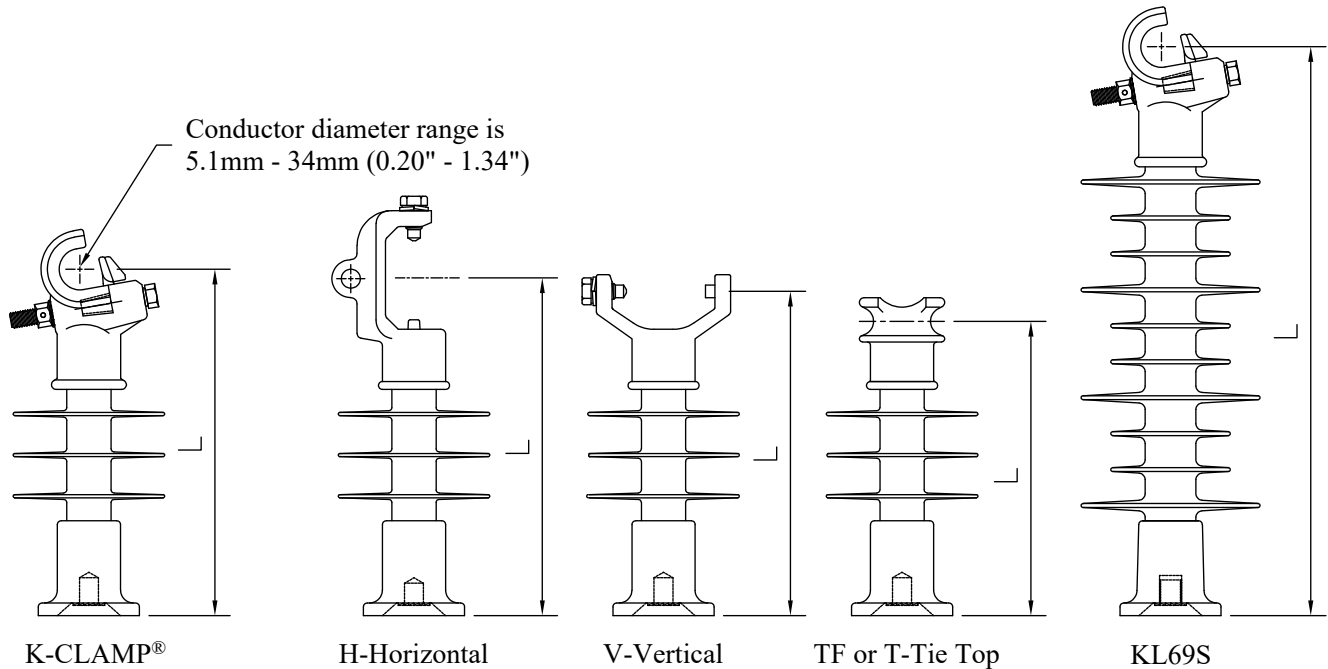

### TECHNICAL DATA

SPECIFICATION	UNIT	CATALOGUE NUMBER*						
		KL15S_	KL28S_	KL35S_	KL46S_	KL69S_P	KL69S_	KL69S_P1
Voltage Class	kV	15	28	35	46	69	69	69
CSA Class	-	LP15	LP25	LP28M	LP46	LP46M	LP46M	LP69M
ANSI Class	-	51-1C, 51-1F, 51-11, 51-21, 51-31	51-12, 51-22 51-32	51-3C, 51-3F, 51-13, 51-23, 51-33	51-4C, 51-4F, 51-14, 51-24, 51-34	51-15, 51-25, 51-35	51-15, 51-25, 51-35	51-16, 51-26, 51-36
Section Length (L)***	mm (in)	297 (11.7)	348 (13.7)	424 (16.7)	495 (19.5)	571 (22.5)	619 (24.4)	694 (27.3)
Dry Arcing Distance	mm (in)	138 (5.4)	196 (7.7)	264 (10.4)	339 (13.3)	445 (17.5)	478 (18.8)	551 (21.7)
Leakage Distance	mm (in)	275 (10.8)	420 (16.5)	657 (25.9)	860 (33.9)	1171 (46.1)	1121 (44.1)	1511 (59.5)
Positive Critical Impulse Flashover	kV	130	150	195	240	300	310	360
Low-Frequency Flashover	Dry	75	105	120	145	190	205	235
	Wet	42	75	85	115	150	160	190
Specified Tensile Load (STL)	kN (lb)	22.2 (5000)	22.2 (5000)	22.2 (5000)	22.2 (5000)	22.2 (5000)	22.2 (5000)	22.2 (5000)
Specified Cantilever Load (SCL)	kN (lb)	12.5 (2800)	12.5 (2800)	12.5 (2800)	12.5 (2800)	12.0 (2700)	14.0 (3150)	11.0 (2475)
Max. Design Cantilever Load (MDCL)	kN (lb)	6 (1350)	6 (1350)	6 (1350)	6 (1350)	6.0 (1350)	7.0 (1575)	5.5 (1240)
Number of Sheds	-	2	3	5	6	10	10	13
Approx. Weight	kg (lb)	4.1 (9.0)	4.3 (9.5)	4.8 (10.5)	5.8 (12.8)	7.0 (15.4)	10.1 (22.2)	8.4 (18.4)
Standard Packaging	-	3	3	3	3	3	2	2

\* **Ordering Information**

To catalogue number, add suffix **H** for horizontal, **V** for vertical, **T** for C-neck Tie-top, **TF** for the F-neck Tie-top, or **K** for K-CLAMP®. The standard base thread is 3/4"-10 UNC, except for KL69S\_P1 it has 7/8"-9 UNC. Different base threads are available upon request.

\*\* For KL69S\_P & KL69S\_P1 insulators with 3/4" threaded base, a minimum Grade 5 bolt or stud must be used.

\*\*\* Section lengths are for K-CLAMP® insulators. For others refer to Section Length Adjustment Table under End Fittings.



**K-LINE INSULATORS LIMITED**

50 Passmore Avenue, Toronto, Ontario, Canada M1V 4T1

• Tel.: (416) 292-2008 • E-Mail: [insulators@k-line.net](mailto:insulators@k-line.net) • Web Page: [www.k-line.net](http://www.k-line.net)

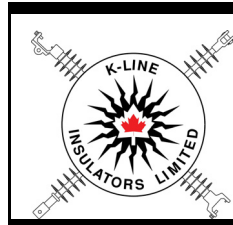

## *New Silicone Line Post Insulator* **For 69 kV Overhead Lines**

**K-LINE INSULATORS LIMITED (KLI)** has introduced a new silicone line post insulator that is applicable for 69 kV overhead lines. This insulator is designed for installations with high electrical requirements. This insulator features the highly reliable proprietary **KLI** silicone rubber that is one piece, injection molded and chemically bonded to a high quality epoxy fiberglass rod.

This insulator will greatly improve the electrical performance of the System, especially in contaminated environments. Insulator contamination is a common problem on overhead lines. The fundamental element for interruptions with contaminated insulators is moisture. Wet atmospheric conditions result in water filming on surfaces and causing leakage currents to develop. On wood structures, leakage currents can cause pole top fires and eventual failures. On steel structures, leakage currents can develop into faults. **KLI's** proprietary silicone rubber offers the ultimate solution in post insulator applications. Because of its hydrophobicity, this material inherently resists water filming thereby limiting leakage currents. These silicone rubber insulators reduce leakage currents, even when contaminated and require less frequent if any washing. The savings in maintenance costs are added benefits of using **KLI** silicone rubber insulators.

The 69 kV line post insulator has been designed to meet the requirements of CSA C411.6, ANSI C29.18, and IEC 61952. The 69 kV line post insulator is available in four different configurations: Horizontal, Vertical, Tie-Top, or K-Clamp®. The K-CLAMP® design offers the best and most cost effective solution in most cases.

### **69 kV K-CLAMP® Line Post**

The K-CLAMP® Line Post insulator has an integral clamp for attaching the conductor directly to the line post insulator without the use of a separate conductor clamp. The K-CLAMP® can be mounted either in the vertical or horizontal position and offers several advantages over conventional line post insulators.

The K-CLAMP® has a smooth clamping zone that accommodates a conductor diameter range of 0.20 inch (5.1 mm) to 1.34 inch (34 mm). The single galvanized steel clamp bolt that secures the keeper can be operated with hot line tools from either side of the clamp. It also extends beyond the clamp body to allow for the attachment of stringing devices.

The K-CLAMP® provides substantial labour cost savings in stringing, sagging and conductor clamping. There are other savings that can be achieved in shipping, stocking and maintenance.

#### **NOTE:**

The K-CLAMP® is designed for use with both bare and covered conductors



## Configuration & Hardware Accessories

The 69 kV line post is available in three other configurations: vertical, horizontal, or tie-top (ANSI F-Neck). Also, the horizontal line post can be supplied with a gain base (See below). Conductor clamps are also available.

**Vertical**



**Tie-Top**



**Horizontal with Gain Base**

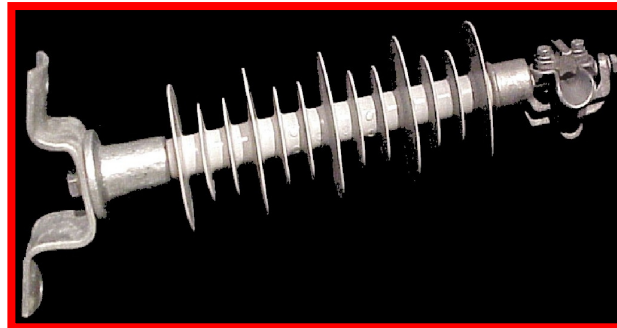

## Technical Data

SPECIFICATION	UNIT	CATALOGUE NUMBER*	SPECIFICATION	UNIT	CATALOGUE NUMBER*	
		KL69S			KL69S	
Voltage Class	kV	69	Radio Influence Voltage (RIV) at 1 MHz	Test	kV	45
				Max	µV	6
CSA Class	-	LP69M	Specified Tensile Load (STL)	kN (lb)	22 (5000)	
ANSI Class	-	51-16 & 51-26	Specified Cantilever Load (SCL)	kN (lb)	11 (2475)	
Dry Arcing Distance	mm (in)	551 (21.7)	Max. Design Cantilever Load (MDCL)	kN (lb)	5.5 (1240)	
Leakage Distance	mm (in)	1511 (59.5)	Approx. Weight	kg (lb)	8.0 (17.5)	
Critical Impulse Flashover (Positive)	kV	360	Standard Packaging	-	2	
Low-Frequency Flashover	Dry	kV	235			
	Wet	190**				

### \* Ordering Information

To Line Post Catalogue Number, add suffix **KP1** for K-CLAMP®, **HP1** for horizontal, **VP1** for vertical, or **TFP1** for tie-top. The standard base thread is 7/8"-9 UNC. Different base threads are available upon request.

\*\* The value shown is as per CSA and the ANSI value is 165 kV.



### K-LINE INSULATORS LIMITED

50 Passmore Avenue, Toronto, Ontario, Canada M1V 4T1

• Tel.: (416) 292-2008 • E-Mail: [insulators@k-line.net](mailto:insulators@k-line.net) • Web Page: [www.k-line.net](http://www.k-line.net)



**K-LINE INSULATORS LIMITED**  
TORONTO, ONTARIO, CANADA

# Catalogue D-SP

## **DISTRIBUTION SILICONE INSULATORS** *Station Post* *15 kV to 46 kV*

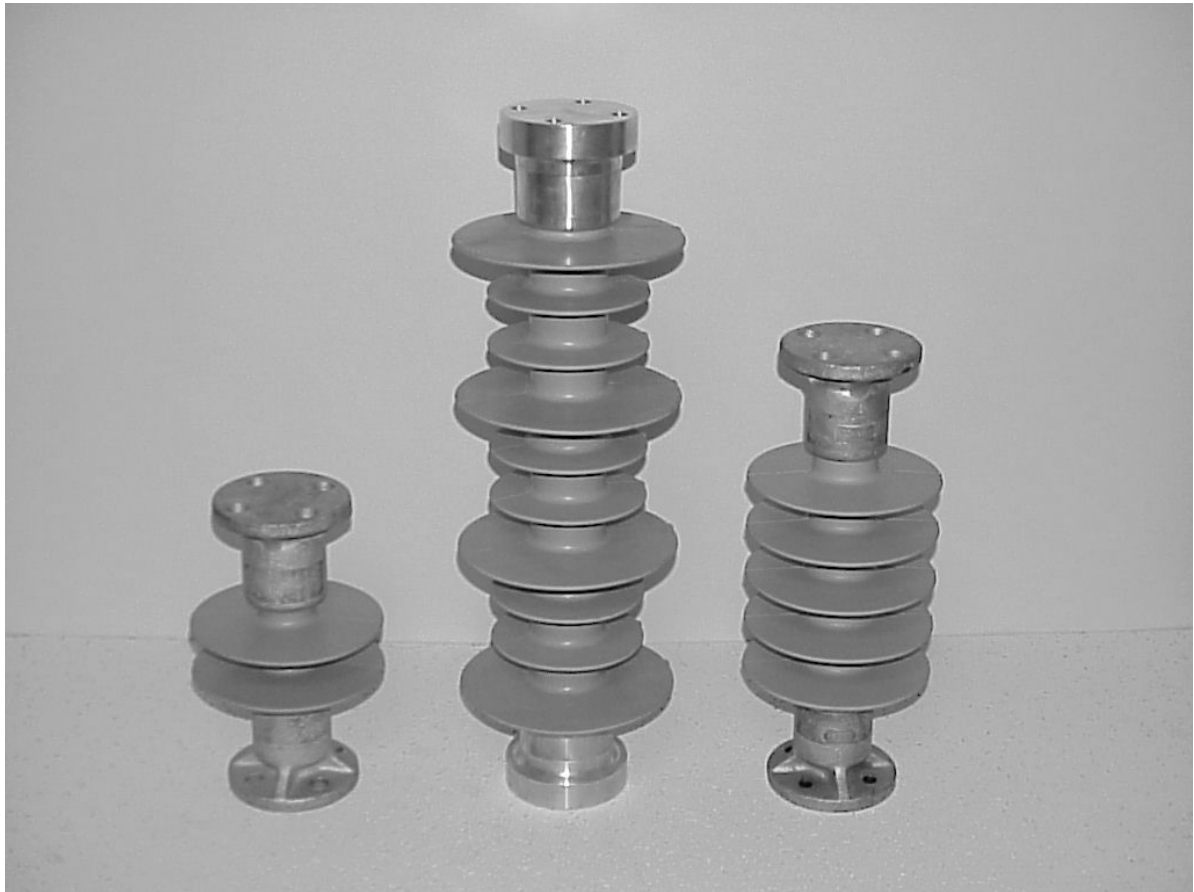

ISO9001  
SAI GLOBAL  
FILE No. 000117

# Distribution Silicone Insulators Station Post

One of the most critical assets of an electrical Distribution System is the station. Not only is this asset the heart of the supply to large electrical loads but it also serves many customers from industrial to residential. Therefore, power outages or interruptions due to insulation failures are costly and impact negatively on customer service. With **K-LINE INSULATORS LIMITED (KLI)** silicone Station Post Insulators these are greatly minimized through improved performance to reliability and savings in the life cycle cost.

Silicone's hydrophobic property allows **KLI** Station Post Insulators to electrically outperform ceramic insulators. The lightweight feature of polymer insulators makes them easy to handle and install. The size and fittings of polymer Station Post Insulators ensure that they are compatible with existing Station Post hardware and arrangements. Experience with silicone polymer insulators has proven their superiority over ceramic insulators.

**KLI** silicone Distribution Station Post Insulators are manufactured and tested in accordance with industry wide standards, CSA and ANSI.

**K-LINE INSULATORS LIMITED** is registered to ISO 9001 Quality Systems.

## PERFORMANCE BENEFITS

The performance benefits of **KLI** Distribution Station Post Insulators are listed below.

- Improves Reliability (by mitigating interruptions and outages due to vandalism, and flashovers in all types of environments)
- Eliminates or Reduces Maintenance (such as washing and trouble calls) and are compatible with existing installation
- Improves Power Quality (lower RI and TVI)
- Energy Efficiency (reduced losses due to lower leakage currents)
- Safety (light weight for handling and installation, eliminates catastrophic mechanical failures)
- Service Life (consistent performance over its service life)
- Life Cycle Cost (savings over ceramic insulators)

## APPLICATION

Distribution Station Post Insulators are used in open-type stations operating at and below 46 kV. These insulators support the bus, leads, or other apparatus within the station.

## CORE ROD

The core rod of the insulator is made of a high quality, epoxy resin, E-Glass fiberglass rod that has been specially formulated for electrical and mechanical applications.

## HOUSING

The housing (includes sheath and sheds) of the insulator is one piece, high temperature vulcanized, injection molded silicone rubber that is chemically bonded to the core rod. This ensures that the interface between the rubber and rod is impenetrable against moisture ingress. **KLI** uses its own proprietary silicone rubber formula in the manufacture of its insulators. The formulation has silicone rubber as the base polymer material with additives to enhance its performance in wet and contaminated environments.

# DISTRIBUTION STATION POST INSULATORS

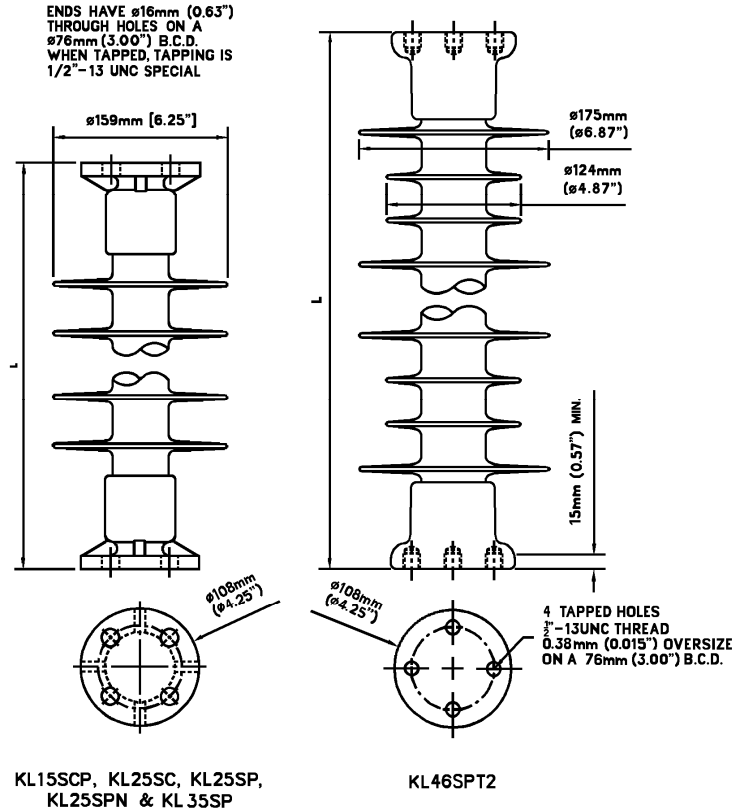

## TECHNICAL DATA

SPECIFICATION	UNIT	CATALOGUE NUMBER*							
		KL15SCP	KL25SC	KL25SP	KL25SPN	KL35SP	KL46SPT2	KL46SPP	
Voltage Class	kV	15	25	28	28	35	46	46	
ANSI Technical Reference (TR)	No.	4 & 205	7	208	10	210	214	214	
Section Length (L)	mm (in)	254 (10)	305 (12)	356 (14)	381 (15)	457 (18)	559 (22)	559 (22)	
Dry Arcing Distance	mm (in)	145 (5.7)	184 (7.2)	259 (10.2)	267 (10.5)	339 (13.3)	478 (18.8)	460 (18.1)	
Leakage Distance	mm (in)	275 (10.8)	420 (16.5)	630 (24.8)	657 (25.9)	860 (33.9)	1121 (44.1)	1201 (47.3)	
Impulse Withstand	kV	125	150	180	185	225	275	295	
Positive Critical Impulse Flashover	kV	130	160	190	195	240	310	310	
Low-Frequency Wet Withstand	kV	40	55	75	75	100	140	150	
Radio Influence Voltage (RIV) at 1000 kHz	Test	kV	10	15	22	22	30	30	-
	Max	$\mu\text{V}$	2.5	2.5	2.5	2.5	2.5	2.5	-
Specified Tensile Load (STL)	kN (lb)	45 (10000)	45 (10000)	45 (10000)	45 (10000)	45 (10000)	45 (10000)	45 (10000)	
Specified Cantilever Load (SCL)	kN (lb)	12.5 (2800)	12.5 (2800)	12.5 (2800)	12.5 (2800)	12.5 (2800)	14.0 (3150)	12.0 (2700)	
Max Design Cantilever Load (MDCL)	kN (lb)	6 (1350)	6 (1350)	6 (1350)	6 (1350)	6 (1350)	7 (1575)	6.0 (1350)	
Number of Sheds	No.	2	3	5	5	6	10	10	
Approx. Weight	kg (lb)	5.0 (11.0)	5.2 (11.5)	5.5 (12.0)	5.9 (12.9)	6.0 (13.4)	9.1 (20.0)	7.0 (15.4)	

### \* Ordering Information:

1. Above catalogue numbers apply to insulators with through holes on both ends. (Except for KL46SPT2).
2. Add T1 to catalogue numbers for insulators with one end tapped & the other with through holes.
3. Add T2 to catalogue number for insulators with both ends tapped.

## END BASES

The standard base fittings are flat round iron bases that are available with bolt circle mounting holes with either through or tapped holes. These bases are compatible with the ceramic Station Post Insulator standard.

The end bases are radially swaged on to the core rod to provide the mechanical performance and reduce the stress concentration. Our proprietary design ensures a watertight seal between the rubber and end fitting. This special silicone rubber to metal fittings sealing process prevents moisture ingress to the core fiberglass rod. For other special base requirements, please contact **KLI**.

Corrosion protection of the end bases is provided by hot-dip galvanizing to CSA G164 or ASTM A153 specifications.

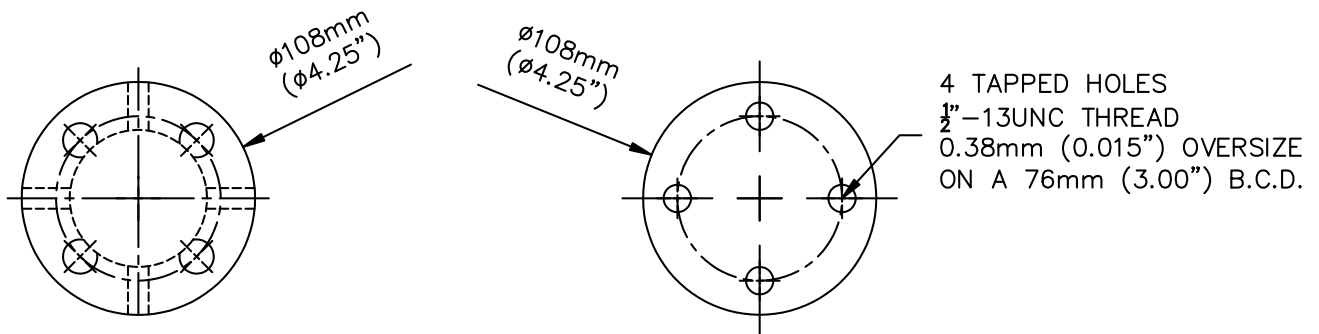

KL15SCP, KL25SC, KL25SP,  
KL25SPN & KL35SP

KL46SPT2



### K-LINE INSULATORS LIMITED

50 Passmore Avenue, Toronto, Ontario, Canada M1V 4T1

• Tel.: (416) 292-2008 • E-Mail: [insulators@k-line.net](mailto:insulators@k-line.net) • Web Page: [www.k-line.net](http://www.k-line.net)



**K-LINE INSULATORS LIMITED**  
TORONTO, ONTARIO, CANADA

# Catalogue T-DS

## **TRANSMISSION SILICONE INSULATORS** *Deadend / Suspension* *69 kV to 400 kV*

---



ISO9001  
SAI GLOBAL  
FILE No. 000117

# Transmission Silicone Insulators

## Deadend / Suspension

One of the most important items on any overhead transmission line is the insulator. This item is the backbone of the transmission system in minimizing interruptions, outages, and assuring system safety and reliability. Therefore, it is essential to have high quality and dependable insulators on the system. With **K-LINE INSULATORS LIMITED** silicone rubber transmission insulators these objectives can be easily achieved with a substantial savings in the life cycle cost.

Experience with silicone polymer insulators has proven their superiority over ceramic insulators. Today more Electric Utilities are shifting to silicone polymer insulators to improve overall performance on transmission lines.

**KLI** Transmission Silicone Suspension/Deadend Insulators are manufactured and test in accordance with industry wide standards, CSA C411.4, ANSI C29.12 and IEC 61109.

**K-LINE INSULATORS LIMITED** is registered to ISO 9001 Quality Systems.

### PERFORMANCE BENEFITS

The performance benefits of **KLI** Transmission Suspension/Deadend Insulators are listed below.

- Improves Reliability (by mitigating interruptions and outages due to vandalism, pole fires, and flashovers in all types of environments)
- Eliminates or Reduces Maintenance (such as washing and trouble calls) and is compatible with existing installation
- Improves Power Quality (less RI and TVI)
- Energy Efficiency (lower losses due to lower leakage currents)
- Safety (light weight for handling and installation)
- Service Life (consistent performance over its service life)
- Life Cycle Cost (savings over ceramic insulators)

### APPLICATION

Transmission Suspension/Deadend Insulators are used on transmission lines operating at and above 60 kV. These insulators are installed on support structures to hold conductors longitudinally (dead-end) or vertically (suspension). The connections to the structure attachment point and line vary depending on the line design or Utilities preference.

### CORE ROD

The core rod of the insulator is made of a high quality, epoxy resin, ECR fiberglass rod that has been specially formulated for electrical and mechanical applications. Each and every rod is subjected to an electrical test to ensure the integrity of the core rods used in the production of all insulators. **KLI**'s rod is a higher torsion strength rating than standard requirements to ensure safer installation and line operation.

### HOUSING

The housing (includes sheath and sheds) of the insulator is one piece, high temperature vulcanized, injection molded silicone rubber that is chemically bonded to the core rod. This ensures that the interface between the rubber and rod is impenetrable against moisture ingress. **KLI** uses its own proprietary silicone rubber formula in the manufacture of its insulators. The formulation has silicone rubber as the base polymer material with additives to enhance its performance in wet and contaminated environments.

## TRANSMISSION DEADEND / SUSPENSION INSULATORS - 90 kN (20,000 lbs)

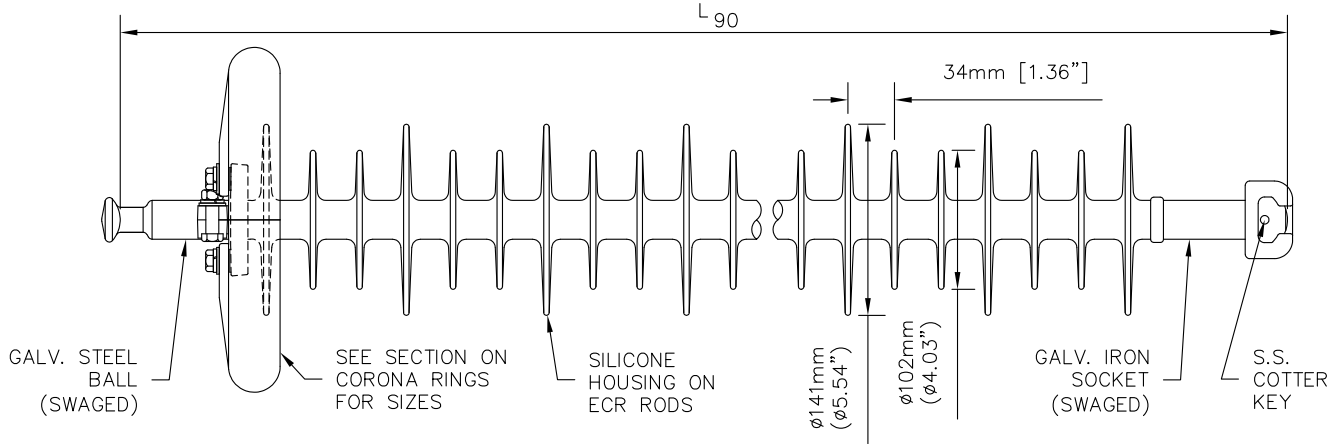

**TECHNICAL DATA:** All values refer to insulators with the appropriate voltage class corona rings installed. (Note 1)

Catalogue Number	Voltage Class	Section Length (Note 2) L	Dry Arcing Distance	Leakage Distance	Positive Critical Impulse Flashover	Impulse Withstand	Low Frequency Dry		Low Frequency Wet		Weight (Note 3)
							Flashover kV	Withstand kV	Flashover kV	Withstand kV	
KL69HB1S113	69	632 (24.9)	526 (20.7)	1466 (57.7)	355	335	215	205	170	150	2.0 (4.3)
KL69HB1S116		737 (29.0)	627 (24.7)	1798 (70.8)	425	400	260	245	205	180	2.4 (5.2)
KL69HB1S119		841 (33.1)	732 (28.8)	2131 (83.9)	485	460	300	285	235	215	2.7 (6.0)
KL115HB1S122	115	942 (37.1)	815 (32.1)	2461 (96.9)	535	505	335	315	265	240	3.3 (7.2)
KL115HB1S125		1046 (41.2)	917 (36.1)	2794 (110.0)	600	565	370	355	300	275	3.6 (8.0)
KL115HB1S128		1150 (45.3)	1021 (40.2)	3127 (123.1)	660	625	415	395	335	310	4.1 (8.9)
KL138HB1S131	138	1252 (49.3)	1125 (44.3)	3460 (136.2)	725	685	455	430	365	340	4.5 (9.8)
KL138HB1S134		1356 (53.4)	1227 (48.3)	3792 (149.3)	785	745	490	465	400	370	4.9 (10.7)
KL138HB1S137		1461 (57.5)	1331 (52.4)	4125 (162.4)	845	805	530	505	430	400	5.2 (11.1)
KL161HB1S140	161	1565 (61.6)	1420 (55.9)	4458 (175.5)	900	855	565	535	460	430	6.6 (14.4)
KL161HB1S143		1666 (65.6)	1521 (59.9)	4790 (188.6)	965	915	605	580	495	460	7.0 (15.3)
KL161HB1S146		1770 (69.7)	1628 (64.1)	5123 (201.7)	1030	980	650	625	535	495	7.4 (16.2)
KL230HB1S149	230	1875 (73.8)	1702 (67.0)	5456 (214.8)	1080	1025	685	660	560	520	7.7 (17.0)
KL230HB1S152		1979 (77.9)	1803 (71.0)	5789 (227.9)	1140	1085	730	705	595	555	8.1 (17.9)
KL230HB1S155		2080 (81.9)	1908 (75.1)	6121 (241.0)	1210	1145	775	750	635	590	8.6 (18.8)

**Notes:**

- See page 8 for correction factors for values for insulators without corona rings.
- Section lengths are based on ANSI ball and socket hardware and 90 kN (20,000 lbs) SML rating. For lengths of insulators with alternate end fittings combination see Section Lengths.
- Weight includes standard rings where applicable. See section on Corona Rings

The formula for the catalogue number of a typical insulator is shown below. For specific catalogue number please contact KLI.

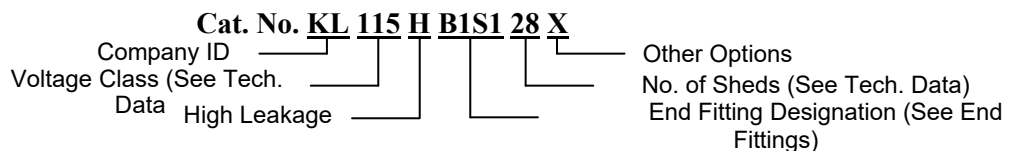

## TRANSMISSION DEADEND / SUSPENSION INSULATORS - 120 kN (27,000 lbs)

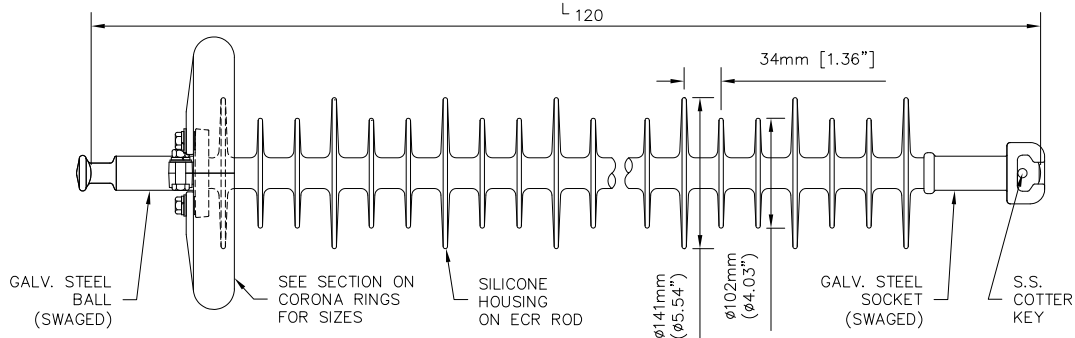

**TECHNICAL DATA:** All values refer to insulators with the appropriate voltage class corona rings installed. (Note 1)

Catalogue Number	Voltage Class	Section Length (Note 2) L	Dry Arcing Distance	Leakage Distance	Positive Critical Impulse Flashover	Impulse Withstand	Low Frequency Dry		Low Frequency Wet		Weight (Note 3)
							Flashover kV	Withstand kV	Flashover kV	Withstand kV	
	kV	mm (in)	mm (in)	mm (in)	kV	kV	Flashover kV	Withstand kV	Flashover kV	Withstand kV	kg (lb)
KL69HBS13	69	660 (26.0)	526 (20.7)	1466 (57.7)	355	335	215	205	170	150	2.9 (6.3)
KL69HBS16		762 (30.0)	627 (24.7)	1798 (70.8)	425	400	260	245	205	180	3.3 (7.2)
KL69HBS19		866 (34.1)	732 (28.8)	2131 (83.9)	485	460	300	285	235	215	3.6 (8.0)
KL115HBS22	115	970 (38.2)	815 (32.1)	2461 (96.9)	535	505	335	315	265	240	4.2 (9.2)
KL115HBS25		1074 (42.3)	917 (36.1)	2794 (110.0)	600	565	370	355	300	275	4.5 (10.0)
KL115HBS28		1176 (46.3)	1021 (40.2)	3127 (123.1)	660	625	415	395	335	310	5.0 (10.9)
KL138HBS31	138	1280 (50.4)	1125 (44.3)	3460 (136.2)	725	685	455	430	365	340	5.4 (11.8)
KL138HBS34		1384 (54.5)	1227 (48.3)	3792 (149.3)	785	745	490	465	400	370	5.8 (12.7)
KL138HBS37		1486 (58.5)	1331 (52.4)	4125 (162.4)	845	805	530	505	430	400	6.1 (13.1)
KL161HBS40	161	1590 (62.6)	1420 (55.9)	4458 (175.5)	900	855	565	535	460	430	7.5 (16.4)
KL161HBS43		1694 (66.7)	1521 (59.9)	4790 (188.6)	965	915	605	580	495	460	7.9 (17.3)
KL161HBS46		1798 (70.8)	1628 (64.1)	5123 (201.7)	1030	980	650	625	535	495	8.3 (18.2)
KL230HBS49	230	1900 (74.8)	1702 (67.0)	5456 (214.8)	1080	1025	685	660	560	520	8.6 (19.0)
KL230HBS52		2004 (78.9)	1803 (71.0)	5789 (227.9)	1140	1085	730	705	595	555	9.0 (19.9)
KL230HBS55		2108 (83.0)	1908 (75.1)	6121 (241.0)	1210	1145	775	750	635	590	9.5 (20.8)
KL230HBS58		2212 (87.1)	2012 (79.2)	6454 (254.1)	1270	1205	815	790	665	620	9.9 (21.8)
KL345HB7S761	345	2314 (91.1)	2144 (84.4)	6787 (267.2)	1350	1285	870	840	710	660	10.3 (22.7)
KL345HB7S764		2418 (95.2)	2248 (88.5)	7120 (280.3)	1415	1345	910	885	745	695	10.7 (23.6)
KL345HB7S767		2522 (99.3)	2357 (92.8)	7452 (293.4)	1480	1410	955	925	785	730	11.5 (25.4)
KL345HB7S770		2624 (103.3)	2461 (96.9)	7785 (306.5)	1545	1470	1000	970	820	765	12.0 (26.3)
KL400HB7S773	400	2728 (107.4)	2512 (98.9)	8118 (319.6)	1580	1500	1020	990	835	780	13.8 (30.3)
KL400HB7S776		2832 (111.5)	2616 (103.0)	8451 (332.7)	1640	1560	1060	1030	870	815	14.1 (31.0)
KL400HB7S779		2935 (115.6)	2649 (104.3)	8783 (345.8)	1660	1580	1075	1045	885	825	14.4 (31.7)

**Notes:**

- See page 8 for correction factors for values for insulators without corona rings.
- Section lengths are based on ANSI ball and socket hardware and 120 kN (27,000 lbs) SML rating. For lengths of insulators with alternate end fittings combination see Section Lengths.
- Weight includes standard rings where applicable. See section on Corona Rings.

The formula for the catalogue number of a typical insulator is shown below. For specific catalogue number please contact **KLI**.

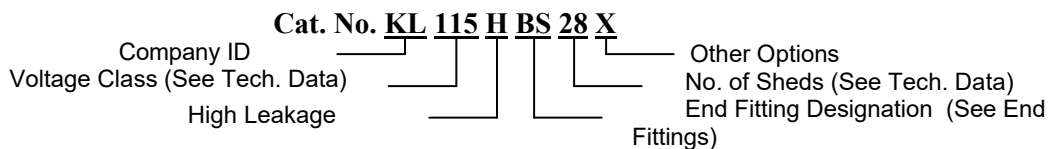

## TRANSMISSION DEADEND / SUSPENSION INSULATORS - 133 kN (30,000 lbs)

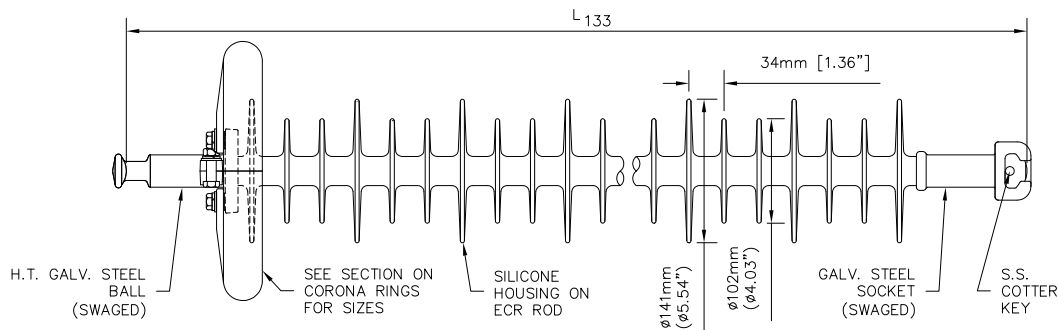

**TECHNICAL DATA:** All values refer to insulators with the appropriate voltage class corona rings installed. (Note 1)

Catalogue Number	Voltage Class	Section Length (Note 2) L	Dry Arcing Distance	Leakage Distance	Positive Critical Impulse Flashover	Impulse Withstand	Low Frequency Dry		Low Frequency Wet		Weight (Note 3)
							Flashover kV	Withstand kV	Flashover kV	Withstand kV	
	kV	mm (in)	mm (in)	mm (in)	kV	kV	Flashover kV	Withstand kV	Flashover kV	Withstand kV	kg (lb)
KL69HBS13D	69	660 (26.0)	523 (20.6)	1466 (57.7)	355	335	215	205	170	150	2.9 (6.3)
KL69HBS16D		762 (30.0)	627 (24.7)	1798 (70.8)	425	400	260	245	205	180	3.3 (7.2)
KL69HBS19D		866 (34.1)	732 (28.8)	2131 (83.9)	485	460	300	285	235	215	3.6 (8.0)
KL115HBS22D	115	970 (38.2)	815 (32.1)	2461 (96.9)	535	505	335	315	265	240	4.2 (9.2)
KL115HBS25D		1074 (42.3)	917 (36.1)	2794 (110.0)	600	565	370	355	300	275	4.5 (10.0)
KL115HBS28D		1176 (46.3)	1021 (40.2)	3127 (123.1)	660	625	415	395	335	310	5.0 (10.9)
KL138HBS31D	138	1280 (50.4)	1128 (44.4)	3460 (136.2)	725	685	455	430	365	340	5.4 (11.8)
KL138HBS34D		1384 (54.5)	1229 (48.4)	3792 (149.3)	785	745	490	465	400	370	5.8 (12.7)
KL138HBS37D		1486 (58.6)	1331 (52.4)	4125 (162.4)	845	805	530	505	430	400	6.1 (13.1)
KL161HBS40D	161	1590 (62.6)	1410 (55.5)	4458 (175.5)	900	855	565	535	460	430	7.5 (16.4)
KL161HBS43D		1694 (66.7)	1514 (59.6)	4790 (188.6)	965	915	605	580	495	460	7.9 (17.3)
KL161HBS46D		1798 (70.8)	1628 (64.1)	5123 (201.7)	1030	980	650	625	535	495	8.3 (18.2)
KL230HBS49D	230	1900 (74.8)	1702 (67.0)	5456 (214.8)	1080	1025	685	660	560	520	8.6 (19.0)
KL230HBS52D		2004 (78.9)	1803 (71.0)	5789 (227.9)	1140	1085	730	705	595	555	9.0 (19.9)
KL230HBS55D		2108 (83.0)	1908 (75.1)	6121 (241.0)	1210	1145	775	750	635	590	9.5 (20.8)
KL230HBS58D	345	2212 (87.1)	2012 (79.2)	6454 (254.1)	1270	1205	815	790	665	620	9.9 (21.8)
KL345HB7S761D		2314 (91.1)	2144 (84.4)	6787 (267.2)	1350	1285	870	840	710	660	10.3 (22.7)
KL345HB7S764D		2418 (95.2)	2248 (88.5)	7122 (280.4)	1415	1345	910	885	745	695	10.7 (23.6)
KL345HB7S767D	400	2522 (99.3)	2357 (92.8)	7452 (293.4)	1480	1410	955	925	785	730	11.5 (25.4)
KL345HB7S770D		2624 (103.3)	2461 (96.9)	7785 (306.5)	1545	1470	1000	970	820	765	12.0 (26.3)
KL400HB7S773D	400	2728 (107.4)	2512 (98.9)	8118 (319.6)	1580	1500	1020	990	835	780	13.8 (30.3)
KL400HB7S776D		2832 (111.5)	2616 (103.0)	8451 (332.7)	1640	1560	1060	1030	870	815	14.1 (31.0)
KL400HB7S779D		2935 (115.6)	2649 (104.3)	8783 (345.8)	1660	1580	1075	1045	885	825	14.4 (31.7)

**Notes:**

- See page 8 for correction factors for values for insulators without corona rings.
- Section lengths are based on ANSI ball and socket hardware and 133 kN (30,000 lbs) SML rating. For lengths of insulators with alternate end fittings combination see Section Lengths.
- Weight includes standard rings where applicable. See section on Corona Rings.

The formula for the catalogue number of a typical insulator is shown below. For specific catalogue number please contact **KLI**.

**Cat. No. KL 115 H BS 28D X**  
 Company ID \_\_\_\_\_ Other Options \_\_\_\_\_  
 Voltage Class (See Tech. Data) \_\_\_\_\_ No. of Sheds (See Tech. Data) \_\_\_\_\_  
 High Leakage \_\_\_\_\_ End Fitting Designation (See End Fittings) \_\_\_\_\_

## TRANSMISSION DEADEND / SUSPENSION INSULATORS - 160 kN (36,000 lbs)

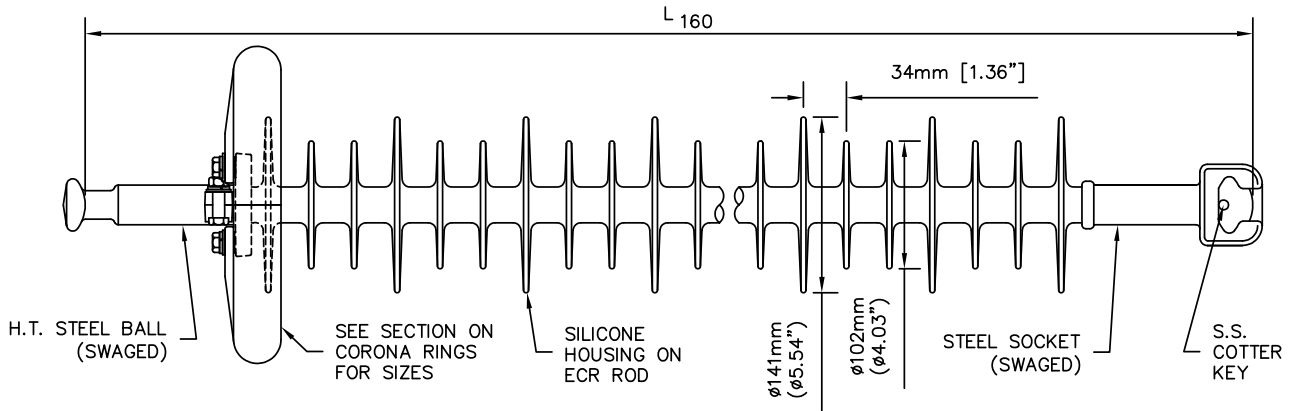

**TECHNICAL DATA:** All values refer to insulators with the appropriate voltage class corona rings installed. (Note 1)

Catalogue Number	Voltage Class	Section Length (Note 2) L	Dry Arcing Distance	Leakage Distance	Positive Critical Impulse Flashover	Impulse Withstand	Low Frequency Dry		Low Frequency Wet		Weight (Note 3)
							Flashover kV	Withstand kV	Flashover kV	Withstand kV	
	kV	mm (in)	mm (in)	mm (in)	kV	kV					kg (lb)
KL161H1BS40	161	1638 (64.5)	1420 (55.9)	4458 (175.5)	900	855	565	535	460	430	7.6 (16.7)
KL161H1BS43		1742 (68.6)	1521 (59.9)	4790 (188.6)	965	915	605	580	495	460	8.0 (17.6)
KL161H1BS46		1847 (72.7)	1626 (64.0)	5123 (201.7)	1030	980	650	625	535	495	8.4 (18.5)
KL230H1BS49	230	1951 (76.8)	1702 (67.0)	5456 (214.8)	1080	1025	685	660	560	520	8.8 (19.3)
KL230H1BS52		2052 (80.8)	1803 (71.0)	5789 (227.9)	1140	1085	730	705	595	555	9.2 (20.2)
KL230H1BS55		2156 (84.9)	1908 (75.1)	6121 (241.0)	1210	1145	775	750	635	590	9.6 (21.1)
KL230H1BS58		2261 (89.0)	2012 (79.2)	6454 (254.1)	1270	1205	815	790	665	620	10.0 (22.0)
KL345HBS61	345	2362 (93.0)	2144 (84.4)	6787 (267.2)	1350	1285	870	840	710	660	10.4 (22.9)
KL345HBS64		2466 (97.1)	2248 (88.5)	7120 (280.3)	1415	1345	910	885	745	695	10.8 (23.8)
KL345HBS67		2573 (101.3)	2357 (92.8)	7452 (293.4)	1480	1410	955	925	785	730	11.5 (25.4)
KL345HBS70		2677 (105.4)	2461 (96.9)	7785 (306.5)	1545	1470	1000	970	820	765	12.0 (26.3)
KL400HBS73	400	2781 (109.5)	2512 (98.9)	8118 (319.6)	1580	1500	1020	990	835	780	13.4 (29.4)
KL400HBS76		2883 (113.5)	2616 (103.0)	8451 (332.7)	1640	1560	1060	1030	870	815	13.8 (30.3)
KL400HBS79		2987 (117.6)	2753 (108.4)	8783 (345.8)	1725	1640	1115	1085	920	855	14.1 (31.0)

**Notes:**

1. See page 8 for correction factors for values for insulators without corona rings.
2. Section lengths are based on ANSI ball and socket hardware and 160 kN (36,000 lbs) SML rating. For lengths of insulators with alternate end fittings combination see Section Lengths.
3. Weight includes standard rings where applicable. See section on Corona Rings.

The formula for the catalogue number of a typical insulator is shown below. For specific catalogue number please contact **KLI**.

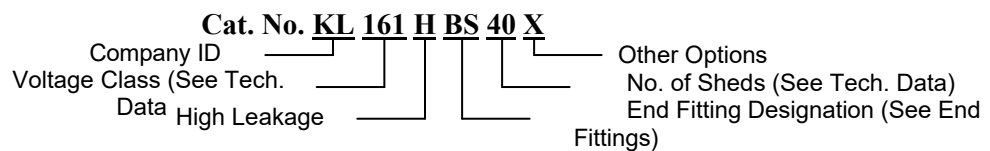

## SECTION LENGTHS

The section lengths, (L) published on the Technical Data sheet, are of insulators with the ANSI Ball and Socket end fittings. For alternate combinations of end fittings, use the following table to establish section lengths.

## SECTION LENGTH ADJUSTMENT

End Fitting	End Fitting Designation		Section Length		
	90 kN	120 kN, 133 kN, & 160 kN	For 90 kN Fittings	For 120 kN & 133 kN Fittings	For 160 kN Fittings
ANSI Ball / Socket	B1S1	BS	L <sub>90</sub> (page 3)	L <sub>120</sub> (page 4 or 5)	L <sub>160</sub> (page 6)
ANSI Ball / Y-clevis	B1Y1	BY	L <sub>90</sub> + 29mm (1.1")	L <sub>120</sub> + 34mm (1.3")	L <sub>160</sub> + 74mm (3.0")
ANSI Ball / Oval Eye	B1E1	BE	L <sub>90</sub> + 45mm (1.8")	L <sub>120</sub> + 39mm (1.5")	L <sub>160</sub> + 65mm (2.6")
Oval Eye / Oval Eye	E1E1	EE	L <sub>90</sub> + 100mm (4.0")	L <sub>120</sub> + 84mm (3.3")	L <sub>160</sub> + 52mm (2.1")
Clevis / Tongue	C3T8	CT	L <sub>90</sub> - 0.3mm (0.1")	L <sub>120</sub> + 21mm (0.8")	-

## CORONA RINGS

High voltage lines above 88 kV phase-to-phase can generate unnecessary noise (RI and TVI) and corona due to the high electrical stress concentration. To minimize these effects, Gradient or Corona Rings are installed on the end fitting of the insulator. Guidelines used in the application of these rings are noted below.

Insulators that are used on system voltages above 88 kV and below 150 kV are supplied with a built-in Gradient Ring. Insulators that are used on system voltages from 150 kV to 275 kV are supplied with a separate Corona Ring for assembly in the field before installation. Above 275 kV an additional ring is required on the ground end fitting. The large rings are designed for installation in only one orientation and location to prevent misapplication. These rings are made from aluminum making them light weight and corrosion resistant.



Ø3-1/4" Gradient Ring  
88 kV to 150 kV

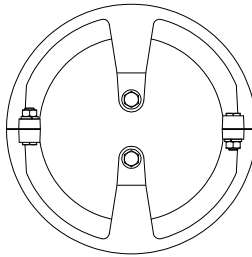

Ø10" Corona Ring  
150 kV to 230 kV

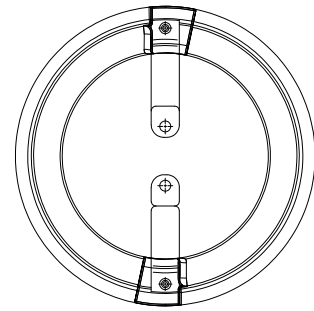

Ø12" Corona Ring  
345 kV to 400 kV

System Voltage (kV)	Energized End		Ground End	
	Ring Needed	Ring Size	Ring Needed	Ring Size
69	No	-	No	-
115	Yes	Φ 3 1/4"	No	-
138	Yes	Φ 3 1/4"	No	-
161	Yes	Φ 10"	No	-
230	Yes	Φ 10"	No	-
275	Yes	Φ 10"	Yes	Φ 3 1/4"
345	Yes	Φ 12"	Yes	Φ 3 1/4"
400	Yes	Φ 12"	Yes	Φ 10"

The values given in the tables on page 3 through 6 refer to insulators complete with the appropriate Corona Rings for the voltage class indicated in the tables. Corona Rings necessarily reduce the dry arc distance for a given insulator and give lower electrical values than could be anticipated for the insulator without rings as shown in the following figure.

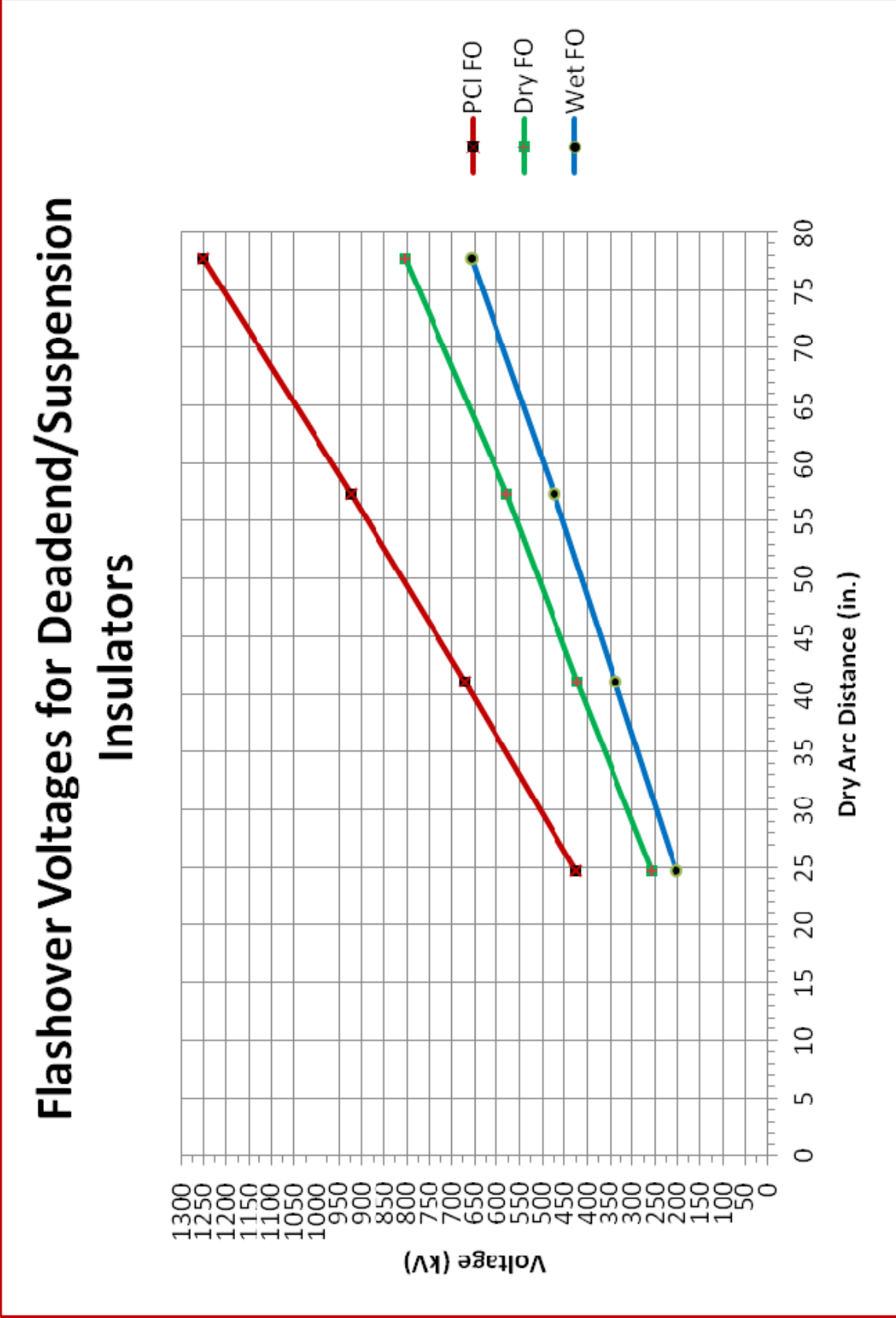

## END FITTINGS

The end fittings on the transmission insulator are made of high strength, forged steel or cast iron. The insulators have a specified mechanical load (SML) rating of 90 kN (20,000 lbs.), 120 kN (27,000 lbs.), 133 kN (30,000 lbs.), or 160 kN (36,000 lbs.). The insulators are routine tension tested to 45 kN (10,000 lbs.), 60 kN (13,500 lbs.), 67 kN (15,000 lbs.) or 80 kN (18,000 lbs.), respectively.

The end fittings are swaged on the core rod to provide the mechanical performance and reduce stress concentration. Our proprietary design ensures a watertight seal between the rubber and end fitting interface. This special silicone rubber to metal fittings to rod sealing process prevents moisture ingress to the fiberglass core rod.

Hot-dip galvanizing to CSA G164 or ASTM A153 Standard provides corrosion protection of the end fittings. The cotter key is made from stainless steel.

The standard end fittings available are listed and detailed below. For other special end fittings, such as Charpy V-notch tested fittings contact **KLI**.

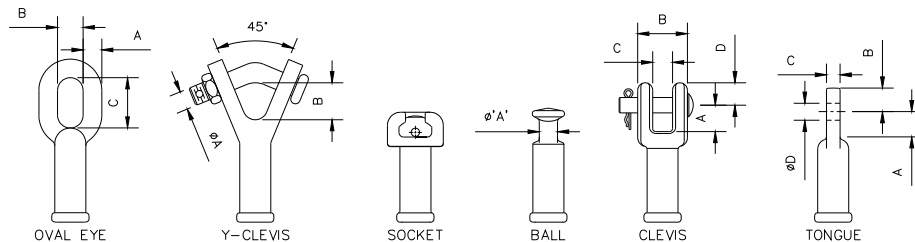

### END FITTING RATINGS AND DIMENSIONS

End Fitting	End Fitting Designation	SML kN (lbs)	Class	Dimensions (in)				
				A	B	C	D	E
Oval Eye	E	90 (20,000)	-	0.75	1.03	2.03	-	-
		120 (27,000)	-	0.75	1.03	2.03	-	-
		133 (30,000)	-	0.75	1.03	2.03	-	-
		160 (36,000)	-	0.78	1.02	2.00	-	-
Y-Clevis	Y	90 (20,000)	-	0.75	1.49	-	-	-
		120 (27,000)	-	0.75	1.49	-	-	
		133 (30,000)	-	0.75	1.49	-	-	
		160 (36,000)	-	0.75	1.89	-	-	
Socket	S	90 (20,000)	ANSI 52-5	-	-	-	-	-
		120 (27,000)	ANSI 52-5	-	-	-	-	
		133 (30,000)	ANSI 52-5	-	-	-	-	
		160 (36,000)	ANSI 52-8	-	-	-	-	
IEC Ball	B_A	90 (20,000)	IEC 16A	16 mm	-	-	-	-
		120 (27,000)	IEC 16A	16 mm	-	-	-	
		133 (30,000)	IEC 16A	16 mm	-	-	-	
		160 (36,000)	IEC 20	20 mm	-	-	-	
ANSI Ball	B	90 (20,000)	ANSI 52-5	0.72	-	-	-	-
		120 (27,000)	ANSI 52-5	0.72	-	-	-	
		133 (30,000)	ANSI 52-5	0.72	-	-	-	
		160 (36,000)	ANSI 52-8	0.88	-	-	-	
Clevis	C	90 (20,000)	ANSI 52-6	1.11	1.69	0.81	0.87	0.63
		120 (27,000)	ANSI 52-6	1.06	2.00	0.80	0.90	0.63
		133 (30,000)	ANSI 52-6	1.06	2.00	0.80	0.90	0.63
		160 (36,000)	ANSI 52-10	1.06	2.00	0.80	0.90	0.63
Tongue	T	90 (20,000)	-	1.11	0.88	0.62	0.69	-
		120 (27,000)	-	1.01	0.96	0.53	0.69	
		133 (30,000)	-	1.01	0.96	0.53	0.69	
		160 (36,000)	-	1.01	0.96	0.53	0.69	



### K-LINE INSULATORS LIMITED

50 Passmore Avenue, Toronto, Ontario, Canada M1V 4T1

• Tel.: (416) 292-2008 • E-Mail: [insulators@k-line.net](mailto:insulators@k-line.net) • Web Page: [www.k-line.net](http://www.k-line.net)



**K-LINE INSULATORS LIMITED**  
TORONTO, ONTARIO, CANADA

# Catalogue T-LP

## **TRANSMISSION SILICONE INSULATORS** *Line Post* *69 kV to 230 kV*



ISO9001  
SAI GLOBAL  
FILE No. 000117

# Transmission Silicone Insulators Line Post

Today transmission lines are required to be more aesthetically pleasing and are routed through narrow right-of-ways or along roadways. At lower transmission voltages (e.g., 115 kV and 69 kV) these lines are routed through urban areas and along roadways similar to distribution circuits to supply substations and larger customers. In some situations these lines share the same route and poles with distribution circuits. With **K-LINE INSULATORS LIMITED (KLI)** silicone rubber Transmission Line Post Insulators an aesthetic compact line design can be easily achieved with a substantial savings in the life cycle cost.

**KLI** silicone rubber Transmission Line Post Insulators are manufactured and tested in accordance with industry wide standards, CSA, ANSI and IEC.

**K-LINE INSULATORS LIMITED** Quality System is registered to ISO 9001 Quality Systems.

## PERFORMANCE BENEFITS

The performance benefits of **KLI** Transmission Line Post Insulators are listed below.

- Improves Reliability (by mitigating interruptions and outages due to vandalism, pole fires, and flashovers in all types of environments)
- Eliminates or Reduces Maintenance (such as washing and less trouble calls) and is compatible with existing installation
- Improves Power Quality (lower RI and TVI)
- Energy Efficiency (reduced losses due to lower leakage currents)
- Safety (light weight for handling and installation)
- Service Life (consistent performance over its service life)
- Life Cycle Cost (savings over ceramic insulators)

## APPLICATION

Transmission Line Post Insulators are used on overhead transmission lines operating at and above 60 kV. These insulators are commonly installed either vertically or horizontally on metal or wooden structures to support the conductor. Also, these insulators are used to support high voltage conductor jumpers or leads.

## CORE ROD

The core rod of the insulator is made of a high quality, epoxy resin, E-Glass fiberglass rod that has been specially formulated for electrical and mechanical applications.

## HOUSING AND SHEDS

The housing (includes sheath and sheds) of the insulator is one piece, high temperature vulcanized, injection molded silicone rubber that is chemically bonded to the core rod. This ensures that the interface between the rubber and rod is impenetrable against moisture ingress. **KLI** uses its own proprietary silicone rubber formula in the manufacture of its insulators. The formulation has silicone rubber as the base polymer material with additives to enhance its performance in wet and contaminated environments.

# TRANSMISSION LINE POST INSULATOR

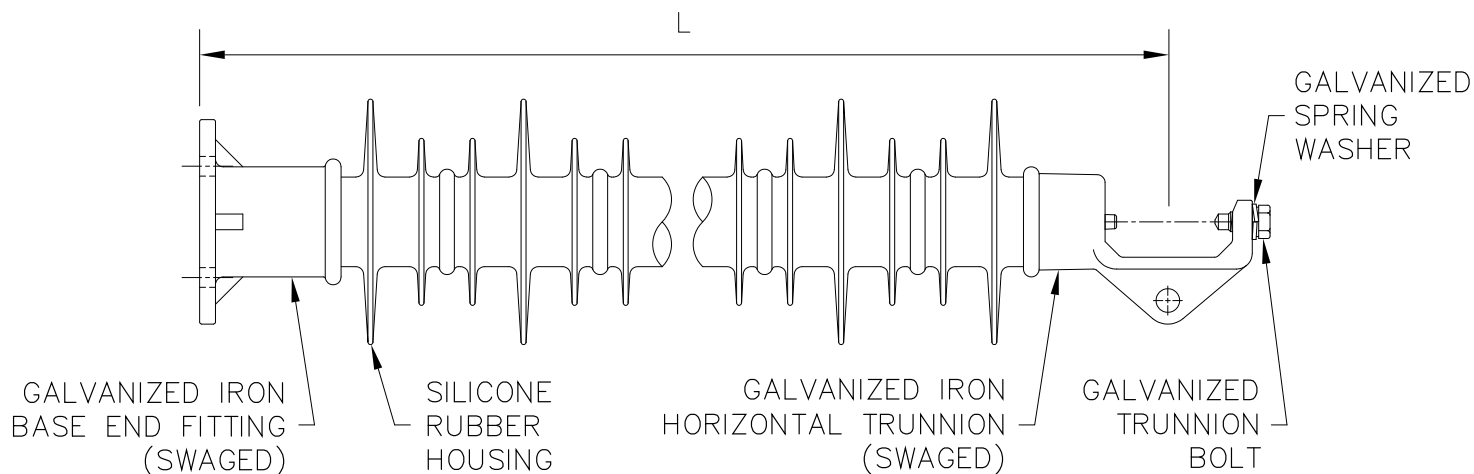

## TECHNICAL DATA

Catalog Number	Voltage Class	Section Length	Dry Arcing Distance	Leakage Distance	Positive Critical Impulse Flashover	Low Frequency Flashover		Specified Cantilever Load (SCL)	Maximum Design Cantilever Load (MDCL)	Specified Tensile Load (STL)*
						Dry	Wet			
		L				mm (in)	mm (in)			
KL69ASH13	69	775 (30.5)	617 (24.3)	1544 (60.8)	380	250	225	27.1 (6090)	13.5 (3045)	22.2 (5000)
KL69ASH16		899 (35.4)	737 (29.0)	1890 (74.4)	450	290	260	24.0 (5410)	12.0 (2705)	22.2 (5000)
KL69ASH19		1022 (40.3)	861 (33.9)	2238 (88.1)	520	340	295	21.1 (4750)	10.6 (2375)	22.2 (5000)
KL115ASH22	115	1147 (45.2)	986 (38.8)	2583 (101.7)	590	385	330	18.2 (4085)	9.1 (2043)	22.2 (5000)
KL115ASH25		1271 (50.0)	1115 (43.9)	2931 (115.4)	665	430	365	15.2 (3415)	7.6 (1707)	22.2 (5000)
KL138ASH28	138	1395 (54.9)	1234 (48.6)	3277 (129.0)	735	475	410	13.8 (3100)	6.9 (1550)	22.2 (5000)
KL138ASH31		1519 (59.8)	1361 (53.6)	3622 (142.6)	805	520	450	12.3 (2775)	6.2 (1388)	22.2 (5000)
KL161ASH34	161	1643 (64.7)	1481 (58.3)	3970 (156.3)	875	555	470	10.8 (2440)	5.4 (1220)	22.2 (5000)
KL161ASH37		1767 (69.5)	1610 (63.4)	4315 (169.9)	955	600	495	9.4 (2105)	4.7 (1053)	22.2 (5000)
KL230ASH22X2	230	2289 (90.1)	2032 (80.0)	5166 (203.4)	1205	740	565	8.0 (1791)	4.0 (896)	22.2 (5000)
KL230ASH25X2		2537 (99.9)	2281 (89.8)	5862 (230.8)	1350	820	605	7.2 (1608)	3.6 (804)	22.2 (5000)
KL230ASH28X2		2766 (108.9)	2540 (100.0)	6553 (258.0)	1505	905	650	6.5 (1469)	3.3 (735)	22.2 (5000)

230kV Post Insulators have a Ø300mm (Ø12") Corona Ring

\*Note: The specified tensile load (STL) of the Two Hole Drop Eye is 66.7 kN (15,000 lbs) and the Vertical Trunnion is 22.2 kN (5000 lbs).

# BASE END FITTINGS

**K-LINE** Transmission Line Post Insulators are available in four base mounting configurations: Bolt Circle Base, Gain Base, Curved Bendable Gain Base, or Flat Bendable Gain Base.

Corrosion protection of the steel or iron end fittings is provided by hot-dip galvanizing to CSA G164 or ASTM A153 specifications. Both the Curved and the Flat Bendable Gain Bases are available in aluminum or steel.

The standard base end fittings available are listed and detailed in the table below. For other special base end fittings contact **KLI**.

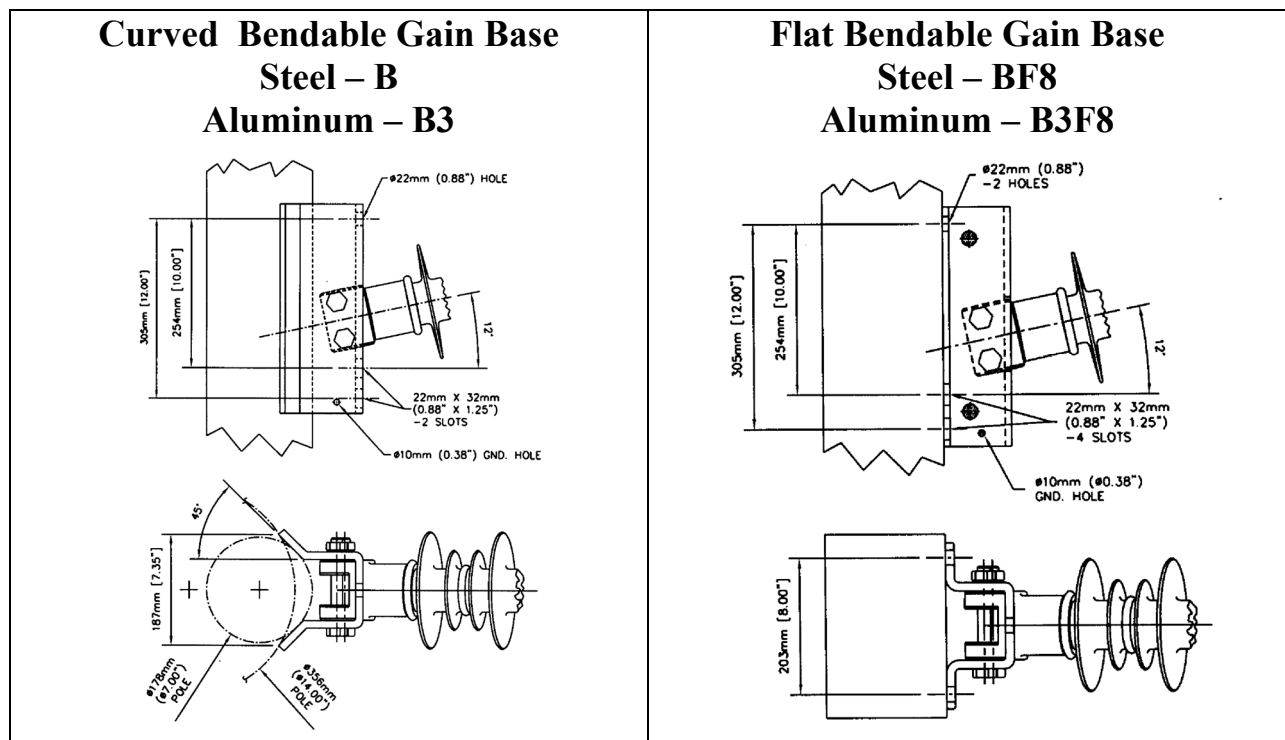
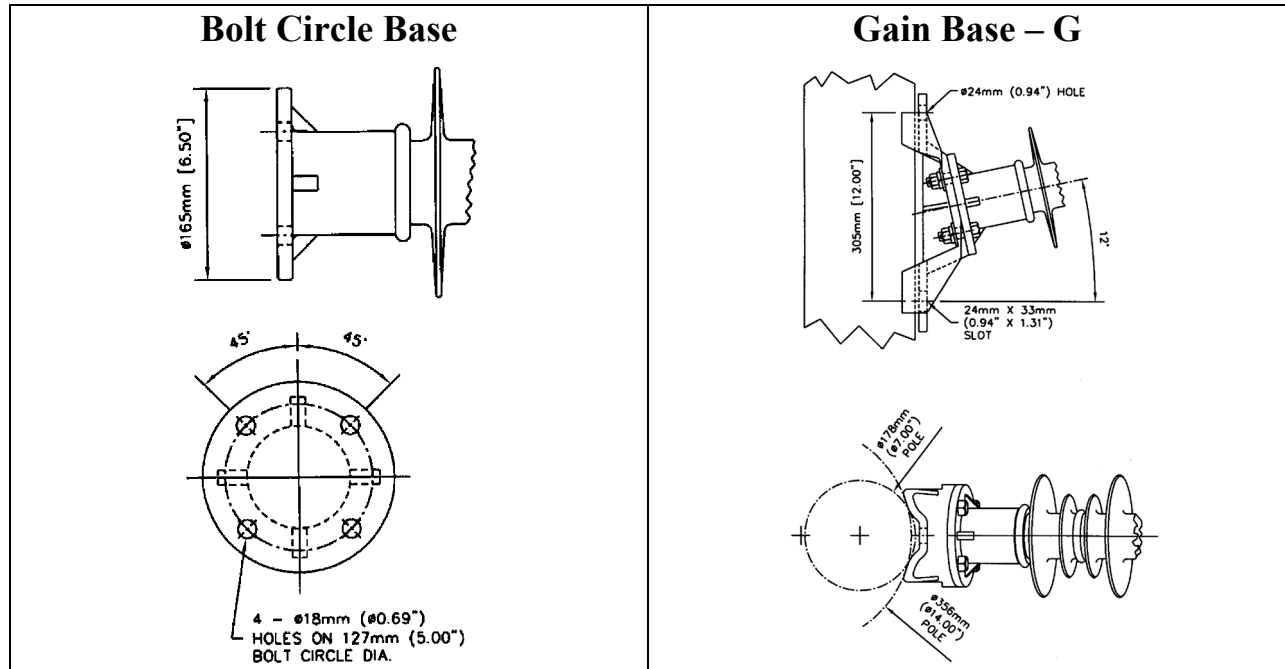

## LINE END FITTINGS

KLI Transmission Line Post Insulators are available with one of the following fittings: Vertical Trunnion, Horizontal Trunnion or Drop Eye. The Vertical and Horizontal Trunnions accommodate a bolted conductor clamp. The Drop Eye is designed for a conductor suspension clamp. The Horizontal Trunnion and Drop Eye end fittings have an additional eye for the attachment of other devices during installation or maintenance activities. All end fittings are made of galvanized iron or steel.

The line end fittings are radially swaged on to the core rod to provide the mechanical performance and to reduce the stress concentration. This along with our proprietary design ensures a watertight seal between the rubber and end fitting. This special silicone rubber to metal end fittings sealing process along with the sheath bond to the fiberglass rod prevents moisture ingress. For other special line fittings please contact KLI.

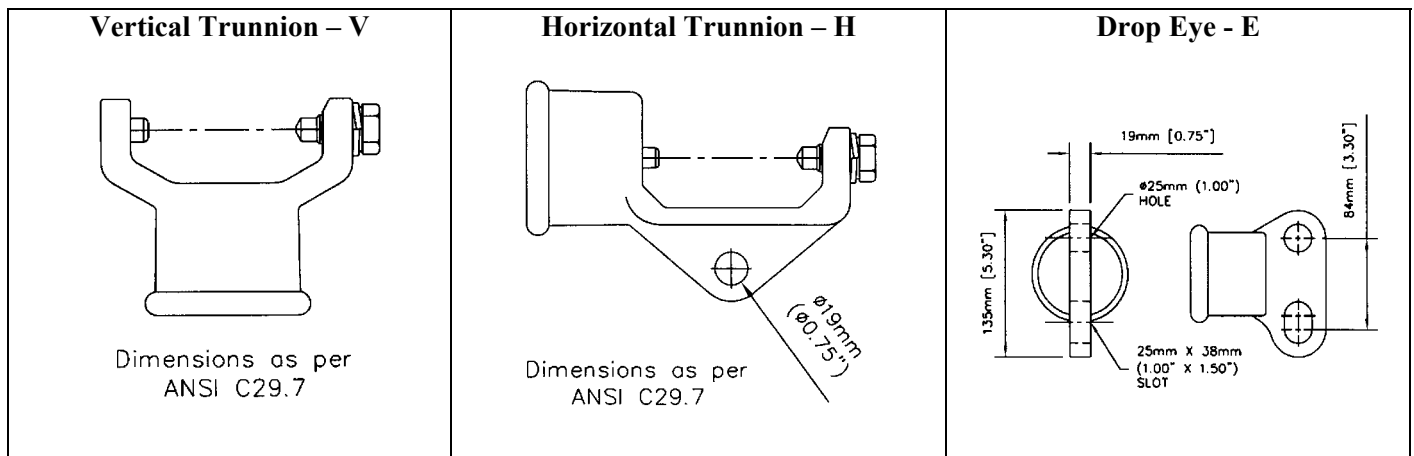

## ORDERING INFORMATION

For ordering, the catalog number of the specific insulator is formulated as shown below:

**Cat. No. KL115ASH 25**

Voltage Class

No. of sheds

Base End Fitting Designation (See Base End Fittings)

Line End Fitting Designation (See Line End Fittings)



### K-LINE INSULATORS LIMITED

50 Passmore Avenue, Toronto, Ontario, Canada M1V 4T1

• Tel.: (416) 292-2008 • E-Mail: [insulators@k-line.net](mailto:insulators@k-line.net) • Web Page: [www.k-line.net](http://www.k-line.net)



K-LINE INSULATORS LIMITED  
TORONTO, ONTARIO, CANADA

# Catalogue T-SP

## TRANSMISSION SILICONE INSULATORS

### *Station Post* *69 kV to 230 kV*

---

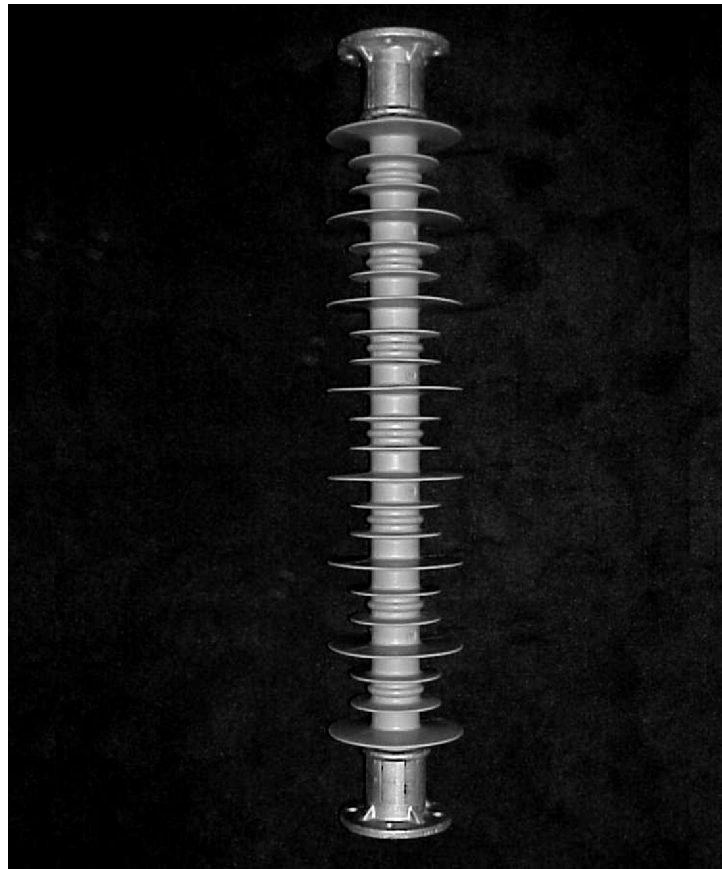

ISO9001  
SAI GLOBAL  
FILE No. 000117

# Transmission Silicone Insulators Station Post

One of the most critical assets of an electrical Transmission System is the station. Not only is this asset the heart of the supply to large electrical loads but it also serves many customers from industrial to residential. Therefore, power outages or interruptions due to insulation failures are costly and impact negatively on customer service. With **K-LINE INSULATORS LIMITED (KLI)** silicone Station Post Insulators these are greatly minimized through improved performance to reliability and savings in the life cycle cost.

Silicone's hydrophobic property allows **KLI** Station Post Insulators to electrically outperform ceramic insulators. The lightweight feature of polymer insulators makes them easy to handle and install. The size and fittings of polymer station insulators are compatible with existing Station Post hardware and arrangements. Experience with silicone polymer insulators has proven their superiority over ceramic insulators.

**KLI** silicone Transmission Station Post Insulators are manufactured and tested in accordance with industry wide standards, CSA and ANSI.

**K-LINE INSULATORS LIMITED** is registered to ISO 9001 Quality Systems.

## PERFORMANCE BENEFITS

The performance benefits of **KLI** Transmission Station Post Insulators are listed below.

- Improves Reliability (by mitigating interruptions and outages due to vandalism, and flashovers in all types of environments)
- Eliminates or Reduces Maintenance (such as washing and trouble calls) and are compatible with existing installation
- Improves Power Quality (lower RI and TVI)
- Energy Efficiency (reduced losses due to lower leakage currents)
- Safety (light weight for handling and installation, eliminates catastrophic mechanical failures)
- Service Life (consistent performance over its service life)
- Life Cycle Cost (savings over ceramic insulators)

## APPLICATION

Transmission Station Post Insulators are used in open-type stations operating at and above 60 kV. These insulators support the bus, leads, or other apparatus within the station.

## CORE ROD

The core rod of the insulator is made of a high quality, epoxy resin, E-Glass fiberglass rod that has been specially formulated for electrical and mechanical applications.

## HOUSING

The housing (includes sheath and sheds) of the insulator is one piece, high temperature vulcanized, injection molded silicone rubber that is chemically bonded to the core rod. This ensures that the interface between the rubber and rod is impenetrable against moisture ingress. **KLI** uses its own proprietary silicone rubber formula in the manufacture of its insulators. The formulation has silicone rubber as the base polymer material with additives to enhance its performance in wet and contaminated environments

# TRANSMISSION STATION POST INSULATOR

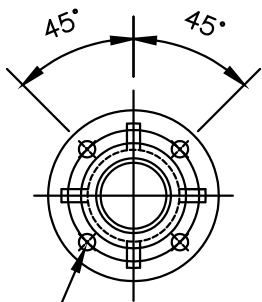

4 -  $\phi 18\text{mm}$  ( $\phi 0.69''$ )  
OR 4 TAPPED HOLES,  
5/8-11 (OVERSIZED)  
ON 127mm (5.00") B.C.D.

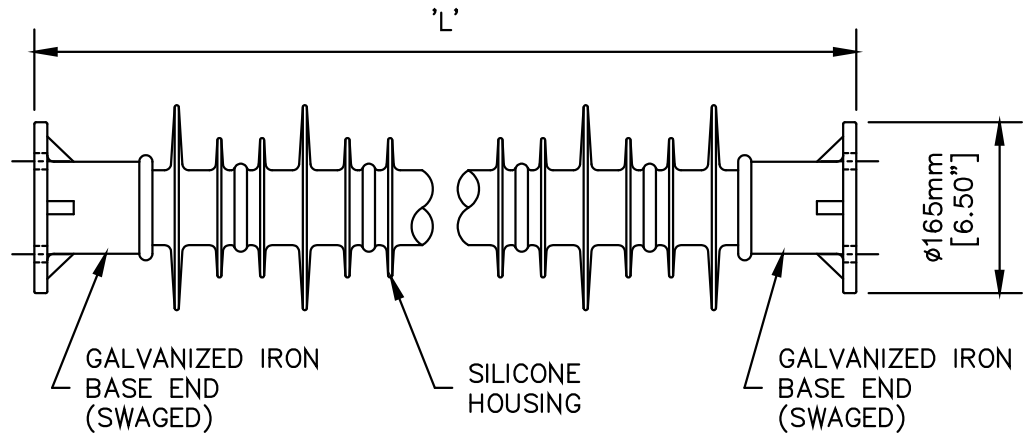

## TECHNICAL DATA

Catalogue Number (See Notes 1, 2, & 3)	Voltage Class	Section Length	Dry Arcing Distance	Leakage Distance	Impulse Withstand	Low Frequency Flashover		Specified Cantilever Load (SCL)	Maximum Design Cantilever Load (MDCL)	Specified Tensile Load (STL)	Approx. Weight	Equivalent Height to ANSI Technical Reference Number
		L				Dry	Wet					
	kV	mm (in)	mm (in)	mm (in)	kV	kV	kV	kN (lbs)	kN (lbs)	kN (lbs)	kg (lbs)	
KL69ASP13	69	762 (30.0)	605 (23.8)	1534 (60.4)	355	245	220	27.1 (6090)	13.5 (3045)	120 (27,000)	16.6 (36.5)	TR216/278
KL69ASP16		895 (35.2)	732 (28.8)	1890 (74.4)	425	290	260	24.0 (5410)	12.0 (2705)	120 (27,000)	18.4 (40.5)	-
KL69ASP19		1019 (40.1)	856 (33.7)	2238 (88.1)	495	335	295	21.1 (4750)	10.6 (2375)	120 (27,000)	19.8 (43.5)	-
KL115ASP22	115	1143 (45.0)	991 (39.0)	2583 (101.7)	565	385	330	18.2 (4085)	9.1 (2043)	120 (27,000)	21.6 (47.5)	TR286/287
KL115ASP25		1267 (49.9)	1115 (43.5)	2931 (115.4)	635	430	365	15.2 (3415)	7.6 (1707)	120 (27,000)	23.0 (50.5)	-
KL138ASP28	138	1372 (54.0)	1220 (48.0)	3256 (128.2)	690	470	405	13.8 (3100)	6.9 (1550)	120 (27,000)	24.8 (54.5)	TR288/289
KL138ASP31		1515 (59.6)	1351 (53.2)	3622 (142.6)	760	515	450	12.3 (2775)	6.2 (1388)	120 (27,000)	26.1 (57.5)	-
KL161ASP34	161	1639 (64.5)	1476 (58.1)	3970 (156.3)	830	555	470	10.8 (2440)	5.4 (1220)	120 (27,000)	28.0 (61.5)	-
KL161ASP37		1763 (69.4)	1600 (63.0)	4315 (169.9)	900	595	490	9.4 (2105)	4.7 (1053)	120 (27,000)	29.3 (64.5)	-
KL230ASP22X2	230	2286 (90.0)	2032 (80.0)	5166 (203.4)	1145	740	565	8.0 (1794)	4.0 (897)	120 (27,000)	54.6 (120)	-
KL230ASP25X2		2534 (99.8)	2281 (89.8)	5862 (230.8)	1285	820	605	7.2 (1610)	3.6 (805)	120 (27,000)	57.3 (126)	-
KL230ASP28X2		2743 (108.0)	2494 (98.2)	6515 (256.5)	1405	890	640	6.6 (1482)	3.3 (741)	120 (27,000)	60.0 (132)	-

230kV Post Insulators have a  $\phi 300\text{mm}$  ( $\phi 12''$ ) Corona Ring

### Ordering Information:

1. Above catalogue numbers apply to insulators with through holes on both ends.
2. Add T1 to catalogue numbers for insulators with one end tapped & the other with through holes.
3. Add T2 to catalogue number for insulators with both ends tapped.

## END BASES

The standard base fittings are flat round iron bases that are available with bolt circle mounting holes with either through or tapped holes. These bases are compatible with the ceramic Station Post Insulator standard.

The end bases are radially swaged onto the core rod to provide the mechanical performance and reduce stress concentration. Our proprietary design insures a watertight seal between the rubber and end fitting. This special silicone rubber to metal fittings sealing process prevents moisture ingress to the fiberglass core rod. For other special base requirements, please contact **KLI**.

Corrosion protection of the end bases is provided by hot-dip galvanizing to CSA G164 or ASTM A153 specifications.

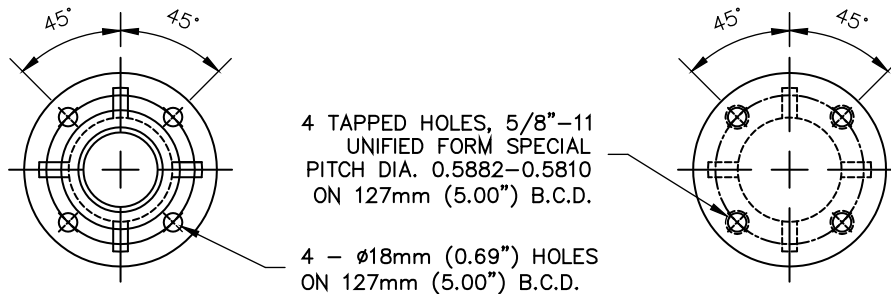

## 230kV & ABOVE

Station Post insulators can be stacked to achieve higher voltage classes. Stacked posts have the advantage of easier transportation, lighter weight for handling and installation.

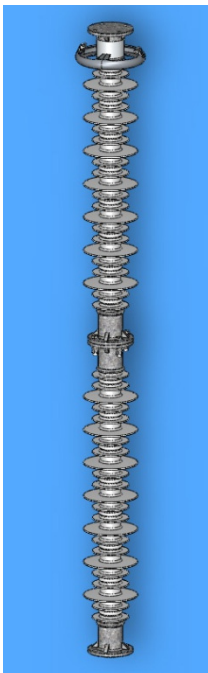

### K-LINE INSULATORS LIMITED

50 Passmore Avenue, Toronto, Ontario, Canada M1V 4T1

• Tel.: (416) 292-2008 • E-Mail: [insulators@k-line.net](mailto:insulators@k-line.net) • Web Page: [www.k-line.net](http://www.k-line.net)



**K-LINE INSULATORS LIMITED**  
TORONTO, ONTARIO, CANADA

# Catalogue GI

## Silicone Guy Strain Insulators

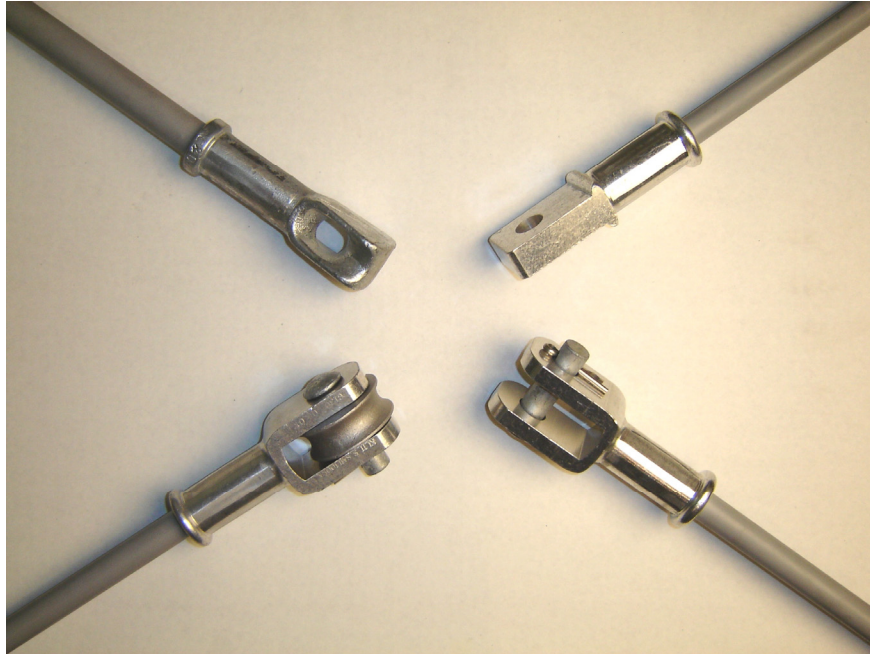

Safety codes mandate the electrical strength of Guy Strain Insulators have a dry flashover voltage at least twice the voltage to ground of the highest voltage supply circuit with which the guy could come in contact, and a wet flashover equal to the highest voltage between any two conductors. When using porcelain, two or more insulators are usually needed to comply with these requirements.

Fiberglass Guy Strain Insulators so located that there is a possibility of contact with the supply conductors are prone to electrical tracking and failure. Paint coatings are easily removed in handling, and by weathering, and do not adequately protect the rod. Unprotected fiberglass core rod exposed to the elements can fail as a result of brittle fracture.

**K-LINE INSULATORS LIMITED (KLI)** Guy Strain Insulators are available with various end fittings and in various lengths. They are protected from the environment including the effects of voltage, ultra-violet rays and acid rain by a fully bonded, electrically track-free, and impenetrable silicone rubber sheath. The electrical and mechanical requirements of the safety codes are easily met by **KLI** Silicone Guy Strain Insulators. Each assembled insulator is proof tested, and permanently marked to show the date of test.

**K-LINE INSULATORS LIMITED** is registered to ISO 9001 Quality Systems.



ISO9001  
SAI GLOBAL  
FILE No. 000117

## GUY STRAIN INSULATORS

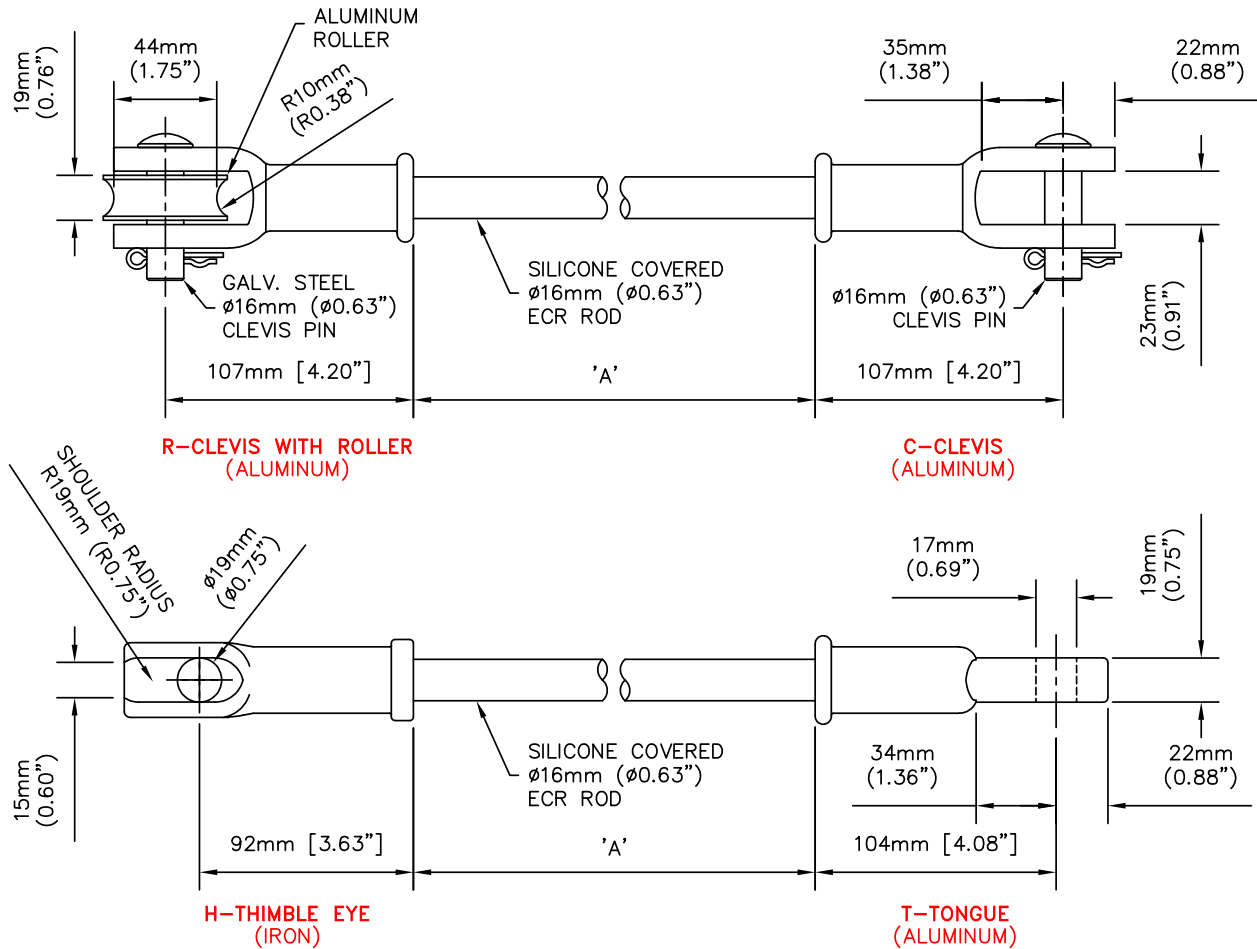

## TECHNICAL DATA

Catalogue Number**	CSA Class	Insulated Length A**	Low Frequency Flashover		Specified Mechanical Load (SML)	Routine Test Load (RTL)	Specified Torsional Load (ST <sub>0</sub> L)	Approx. Weight
			Dry	Wet				
			kV	kV				
KL11	GI30	280 (11)	120	65	100 (22,500)	50 (11,250)	56 (42)	0.6 (1.3)
KL24	GI60	610 (24)	240	150	100 (22,500)	50 (11,250)	56 (42)	0.7 (1.5)
KL36	GI90	910 (36)	340	240	100 (22,500)	50 (11,250)	56 (42)	0.9 (2.0)
KL54	GI140	1370 (54)	505	360	100 (22,500)	50 (11,250)	56 (42)	1.5 (3.3)
KL78	GI200	1980 (78)	810	505	100 (22,500)	50 (11,250)	56 (42)	2.0 (4.4)
KL96	N/A	2438 (96)	1030	615	100 (22,500)	50 (11,250)	56 (42)	2.5 (5.5)

\* To catalogue number, add suffix **CTS** for Clevis-Tongue, **CCS** for Clevis-Clevis, **CRS** for Clevis-Roller, **RRS** for Roller-Roller, or **HHSF** for Thimble Eye- Thimble Eye, **T** for Tongue, (other custom fittings can be accommodated).

Other lengths are available on request.



### K-LINE INSULATORS LIMITED

50 Passmore Avenue, Toronto, Ontario, Canada M1V 4T1

• Tel.: (416) 292-2008 • E-Mail: [insulators@k-line.net](mailto:insulators@k-line.net) • Web Page: [www.k-line.net](http://www.k-line.net)

## GUY STRAIN INSULATORS

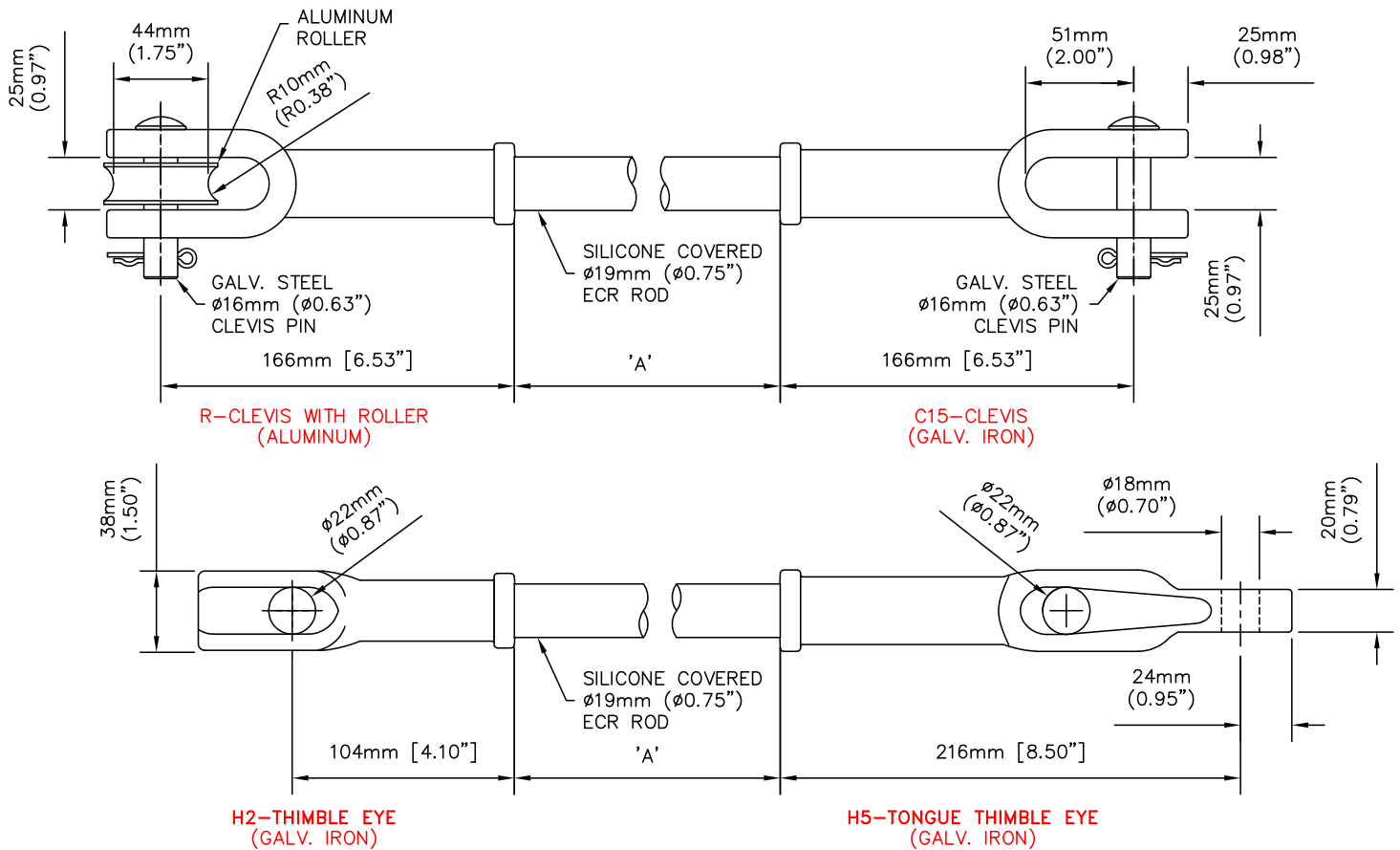

## TECHNICAL DATA

Catalogue Number**	CSA Class	Insulated Length A**	Low Frequency Flashover		Specified Mechanical Load (SML)	Routine Test Load (RTL)	Specified Torsional Load (ST <sub>0</sub> L)	Approx. Weight
			Dry	Wet				
			kV	kV				
KL11**S4	GI30	280 (11)	120	65	100 (22,500)	50 (11,250)	83 (62)	2.4 (5.2)
KL24**S4	GI60	610 (24)	240	150	100 (22,500)	50 (11,250)	83 (62)	2.7 (5.9)
KL36**S4	GI90	910 (36)	340	240	100 (22,500)	50 (11,250)	83 (62)	3.0 (6.5)
KL54**S4	GI140	1370 (54)	505	360	100 (22,500)	50 (11,250)	83 (62)	3.4 (7.5)
KL78**S4	GI200	1980 (78)	810	505	100 (22,500)	50 (11,250)	83 (62)	4.0 (8.7)
KL96**S4	N/A	2438 (96)	1030	615	100 (22,500)	50 (11,250)	83 (62)	4.4 (9.6)

\*\* To catalogue number, insert **C15** for clevis, **H2** for Thimble Eye, **H5** for Tongue Thimble Eye, **R** for Clevis with Roller, (other custom fittings can be accommodated).

Other lengths are available on request.



### K-LINE INSULATORS LIMITED

50 Passmore Avenue, Toronto, Ontario, Canada M1V 4T1

• Tel.: (416) 292-2008 • E-Mail: [insulators@k-line.net](mailto:insulators@k-line.net) • Web Page: [www.k-line.net](http://www.k-line.net)

## GUY STRAIN INSULATORS

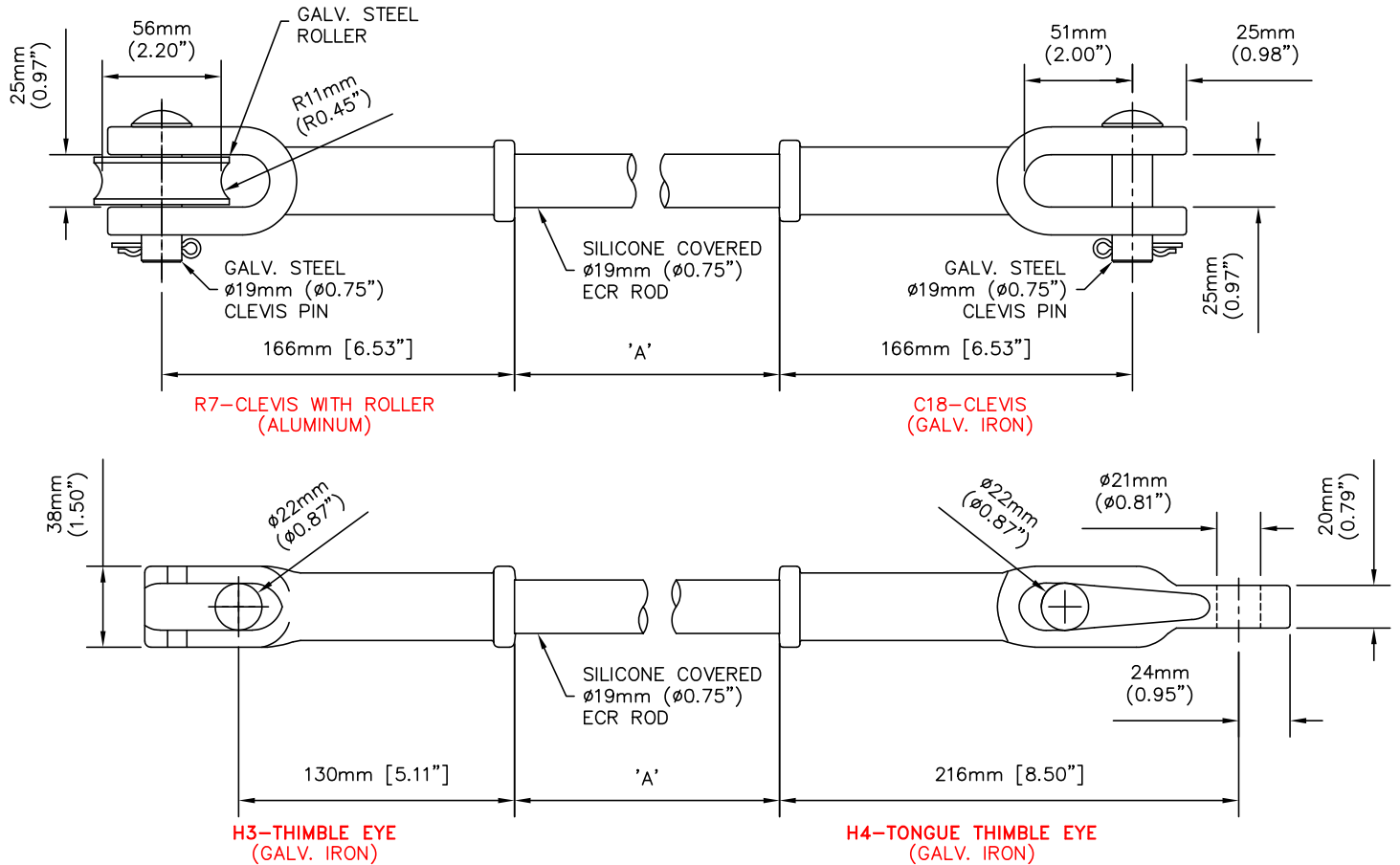

## TECHNICAL DATA

Catalogue Number**	CSA Class	Insulated Length A**	Low Frequency Flashover		Specified Mechanical Load (SML)	Routine Test Load (RTL)	Specified Torsional Load (ST <sub>0</sub> L)	Approx. Weight
			Dry	Wet				
			mm (in)	kV				
KL11**S4	GI30	280 (11)	120	65	160 (36,000)	80 (18,000)	83 (62)	3.0 (6.5)
KL24**S4	GI60	610 (24)	240	150	160 (36,000)	80 (18,000)	83 (62)	3.2 (7.0)
KL36**S4	GI90	910 (36)	340	240	160 (36,000)	80 (18,000)	83 (62)	3.5 (7.6)
KL54**S4	GI140	1370 (54)	505	360	160 (36,000)	80 (18,000)	83 (62)	3.9 (8.6)
KL78**S4	GI200	1980 (78)	810	505	160 (36,000)	80 (18,000)	83 (62)	4.5 (9.8)
KL96**S4	N/A	2438 (96)	1030	615	160 (36,000)	80 (18,000)	83 (62)	4.8 (10.7)

\*\* To catalogue number, insert **C18** for clevis, **H3** for Thimble Eye, **H4** for Tongue Thimble Eye, **R7** for Clevis with Roller, (other custom fittings can be accommodated).

Other lengths are available on request.



### K-LINE INSULATORS LIMITED

50 Passmore Avenue, Toronto, Ontario, Canada M1V 4T1

• Tel.: (416) 292-2008 • E-Mail: [insulators@k-line.net](mailto:insulators@k-line.net) • Web Page: [www.k-line.net](http://www.k-line.net)



**K-LINE INSULATORS LIMITED**  
**TORONTO, ONTARIO, CANADA**

# **Catalogue EI-ELI**

## **EXTENSION INSULATORS AND EXTENSION LINK INSULATORS**

*15 kV to 69 kV*

---

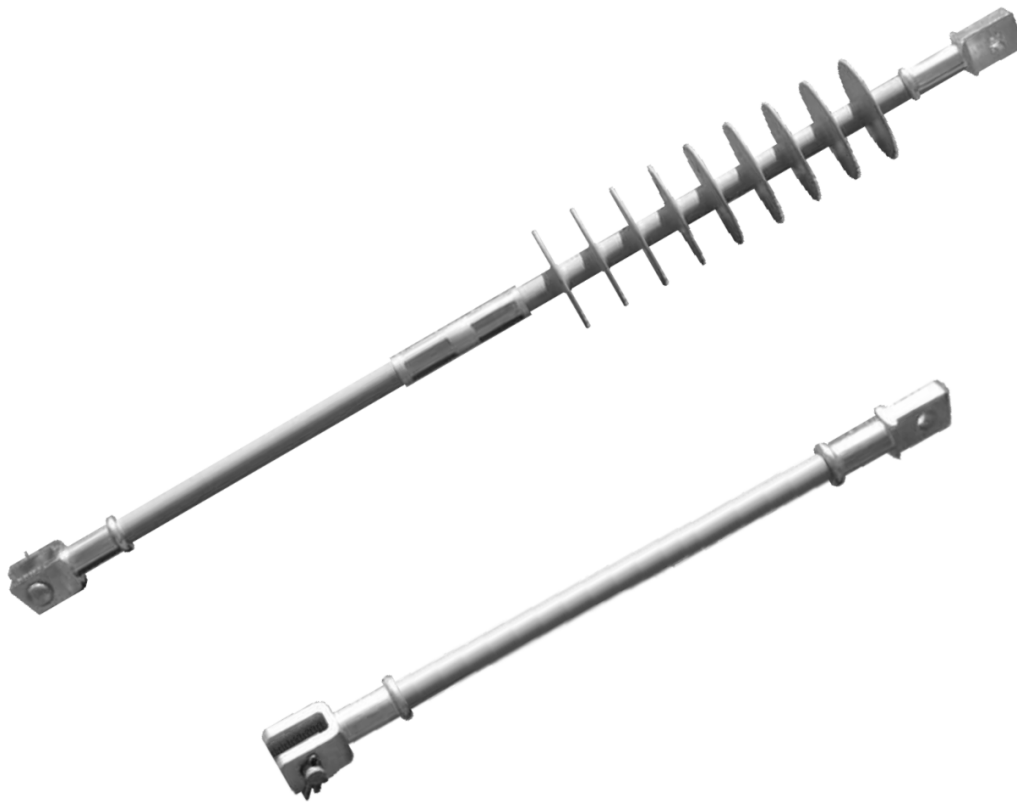

**ISO9001**  
**SAI GLOBAL**  
**FILE No. 000117**

# Extension and Extension Link Insulators

**EXTENSION INSULATORS** are one piece units manufactured by coupling silicone covered core rod to polymer deadend insulators. Extension Insulators are made using the same manufacturing methods and quality assurance program as deadend insulators. Each Extension Insulator is mechanically proof tested to a minimum of 45kN (10,000 lbs).

**EXTENSION LINK INSULATORS** consist of a silicone covered core rod with a variety of end fittings. Each Extension Link Insulator is mechanically proof tested to a minimum of 45kN (10,000 lbs). These can be coupled with an insulator for application requiring extensions or extra clearance.

## PERFORMANCE BENEFITS

The performance benefits of **K-LINE INSULATORS (KLI)** Extension & Extension Link Insulators are similar to all **KLI** standard insulator designs and are listed below.

- Improves Reliability (by mitigating interruptions and outages due to vandalism, pole fires, and flashovers in all types of environments)
- Eliminates or Reduces Maintenance (such as washing and trouble calls) and is compatible with existing installation
- Improves Power Quality (less RI and TVI)
- Energy Efficiency (lower losses due to lower leakage currents)
- Safety (light weight for handling and installation)
- Service Life (consistent performance over its service life)
- Life Cycle Cost (savings over ceramic insulators)

## APPLICATION

Extension Insulators provide additional insulation value and are used on overhead lines operating at or below 69 kV. These insulators are used to support line conductors in deadend modes such as line terminations, angles, and tangents. Extension Link Insulators are designed to be used in series with Deadend Insulators. Extension Insulators and Extension Link Insulators are used to obtain more working clearance and electrical clearance or to move the conductor attachment point away from the structure.

## CORE ROD

The core rod of the insulator is made of a high quality, epoxy resin, E-Glass fiberglass rod that has been specially formulated for electrical and mechanical applications.

## HOUSING

The housing (includes sheath and sheds) of the insulator is one piece, high temperature vulcanized, injection molded silicone rubber that is chemically bonded to the core rod. This ensures that the interface between the rubber and rod is impenetrable against moisture ingress. **KLI** uses its own proprietary silicone rubber formula in the manufacture of its insulators. The formulation has silicone rubber as the base polymer material with additives to enhance its performance in wet and contaminated environments.

## FITTINGS

Extension and Extension Link Insulators come standard with aluminum clevis and tongue end fittings, galvanized iron fittings are also available. Other fitting combinations are available upon request.

# EXTENSION INSULATOR

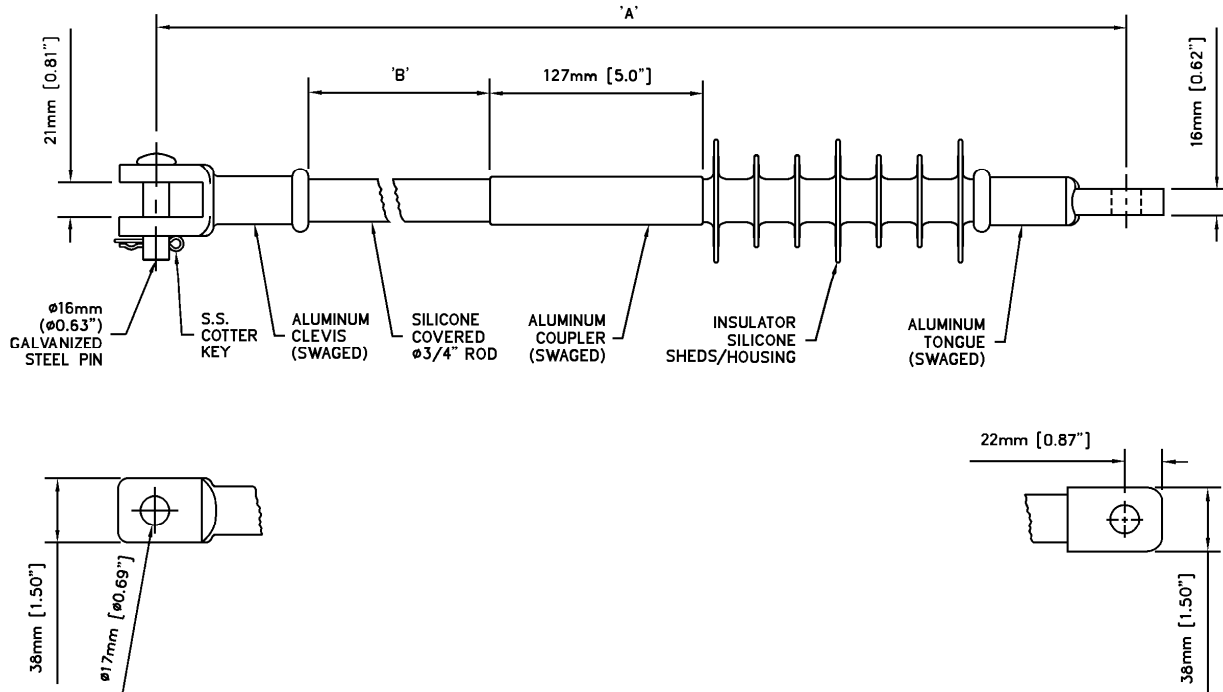

## TECHNICAL DATA

CATALOG NUMBER	VOLTAGE RATING (kV) (See Notes 1 & 2)	DIMENSIONS mm (in)		SPECIFIED MECHANICAL LOAD (SML) kN (lbs)	WEIGHT kg (lbs.)
		'A'	'B'		
KL15ASX11S4	15	761 (29.9")	290 (11.43")	90 (20,230)	1.1 (2.4)
KL15ASX24S4		1091 (42.9")	621 (24.43")	90 (20,230)	1.4 (3.1)
KL15ASX36S4		1369 (54.9")	925 (36.43")	90 (20,230)	1.7 (3.7)
KL15ASX60S4		2005 (78.9")	1535 (60.42")	90 (20,230)	2.2 (4.9)
KL28ASX11S4	28	871 (34.3")	290 (11.43")	90 (20,230)	1.2 (2.6)
KL28ASX24S4		1201 (47.3")	621 (24.43")	90 (20,230)	1.5 (3.3)
KL28ASX36S4		1506 (59.3")	925 (36.43")	90 (20,230)	1.8 (3.9)
KL28ASX60S4		2115 (83.3")	1535 (60.42")	90 (20,230)	2.3 (5.1)
KL35SX11S4	35	924 (36.4")	290 (11.43")	90 (20,230)	1.5 (3.3)
KL35SX24S4		1255 (49.4")	621 (24.43")	90 (20,230)	1.8 (4.0)
KL35SX36S4		1559 (61.4")	925 (36.43")	90 (20,230)	2.1 (4.7)
KL35SX60S4		2169 (85.4")	1535 (60.42")	90 (20,230)	2.7 (5.9)
KL46SX11S4	46	991 (39.0")	290 (11.43")	90 (20,230)	1.7 (3.8)
KL46SX24S4		1321 (52.0")	621 (24.43")	90 (20,230)	2.0 (4.5)
KL46SX36S4		1626 (64.0")	925 (36.43")	90 (20,230)	2.3 (5.1)
KL46SX60S4		2235 (88.0")	1535 (60.42")	90 (20,230)	2.9 (6.4)
KL69H16X11S4	69	1150 (45.3")	290 (11.43")	90 (20,230)	3.0 (6.6)
KL69H16X24S4		1480 (58.3")	621 (24.43")	90 (20,230)	3.3 (7.3)

**Notes:**

- 1) For complete specifications of the, 15-46 kV, insulators, refer to Distribution Insulators – Deadend/Suspension, Catalogue D-DS.
- 2) For complete specifications of the, 69 kV, insulators, refer to Transmission Insulators – Deadend/Suspension, Catalogue T-DS.
- 3) The silicone covered core rod in series with the insulator will provide additional insulation value.
- 4) Standard lengths listed. Custom lengths are available on request.
- 5) End fittings available are: clevis, tongue, thimble eye, oval eye, "y" clevis, socket, ball, etc.

# EXTENSION LINK INSULATOR

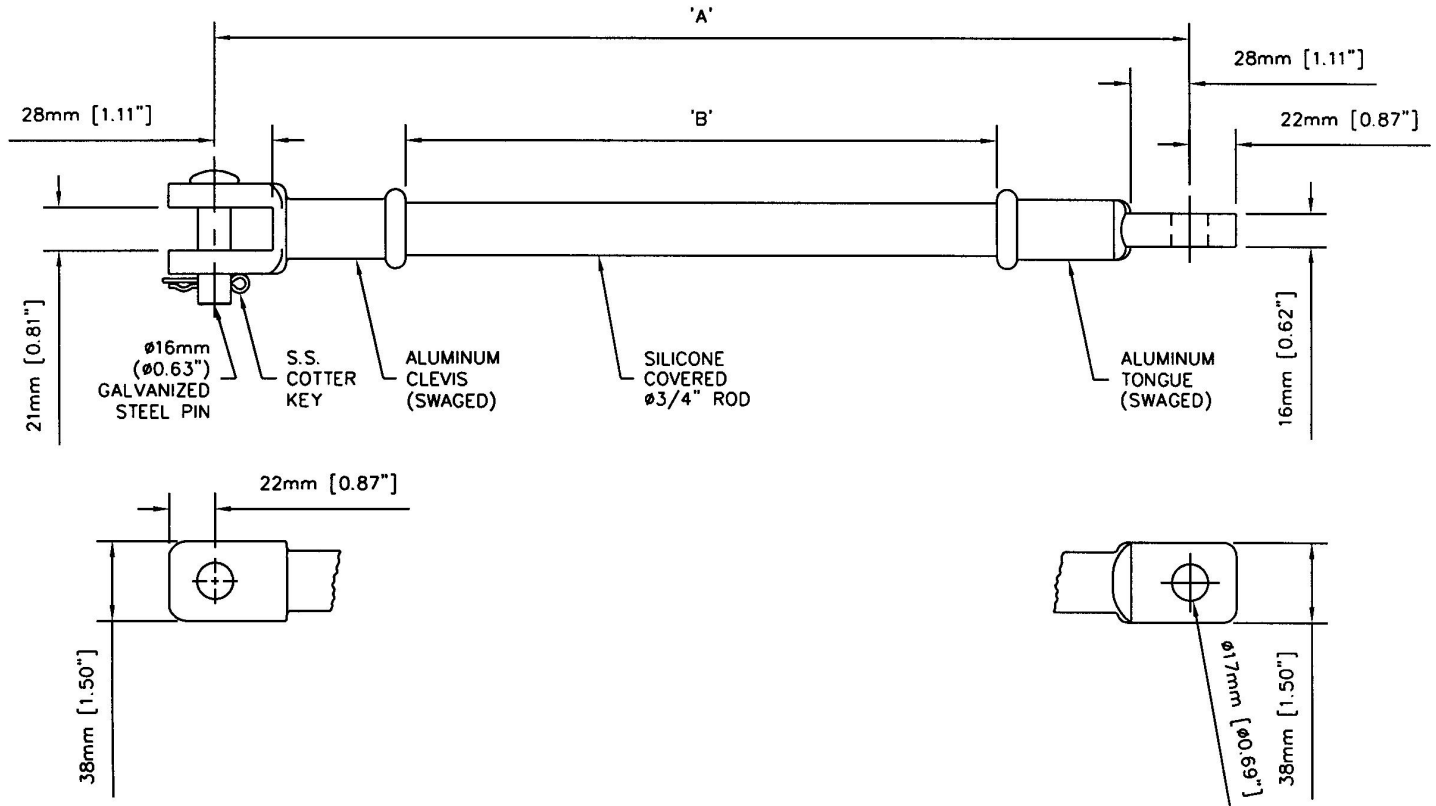

## TECHNICAL DATA

CATALOG NUMBER	DIMENSIONS mm (in)		Specified Mechanical Load (SML) kN (lbs)	WEIGHT kg (lbs.)
	'A'	'B'		
KL11CTS4	464 (18.3")	281 (11.1")	90 (20,230)	0.8 (1.7)
KL24CTS4	797 (31.4")	614 (24.2")	90 (20,230)	1.1 (2.4)
KL36CTS4	1102 (43.4")	919 (36.2")	90 (20,230)	1.4 (3.0)
KL60CTS4	1707 (67.2")	1524 (60.0")	90 (20,230)	1.9 (4.3)

**Notes:**

- 1) Standard lengths listed. Custom lengths are available on request.
- 2) End fittings available are: Clevis, Tongue, Thimble Eye, Oval Eye, "Y" Clevis, Socket, Ball, etc.
- 3) Tested & meets CSA C411.7



**K-LINE INSULATORS LIMITED**

50 Passmore Avenue, Toronto, Ontario, Canada M1V 4T1

• Tel.: (416) 292-2008 • E-Mail: [insulators@k-line.net](mailto:insulators@k-line.net) • Web Page: [www.k-line.net](http://www.k-line.net)



**K-LINE INSULATORS LIMITED**  
TORONTO, ONTARIO, CANADA

# Catalogue TD-IPS

## **TRANSMISSION & DISTRIBUTION**

### **SILICONE INSULATORS**

### *InterPhase Spacers*

### *15 kV to 400 kV*

---

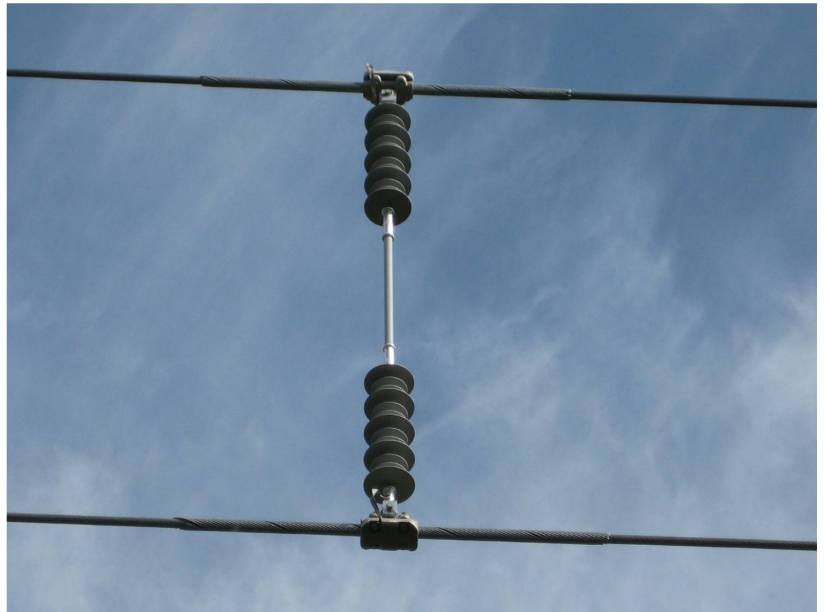

ISO9001  
SAI GLOBAL  
FILE No. 000117

# Transmission & Distribution Silicone InterPhase Spacers

With environmental exposure to ice and/or wind, Overhead Transmission and Distribution Lines are susceptible to conductor motion that may result in outages or interruptions on the electrical system due to conductor contact, flashovers, or plant damage. InterPhase Spacers (IPS) were developed to minimize the probability of these occurrences by maintaining conductor separation.

**K-LINE INSULATORS LIMITED (KLI)** InterPhase Spacers consist of silicone rubber sheds and sheath injection molded over a fiberglass rod and may be coupled with silicone rubber covered rods to increase length. Although lightweight and flexible, InterPhase Spacers are designed to meet the torsional, bending and compression loads of the application. There are a variety of end fittings options available depending on the conductor clamping requirements with or without armour rod. **KLI** InterPhase Spacers meet the requirements of IEC 61109, ANSI C29.13, ANSI C29.12, CSA C411.5 and CSA C411.4.

**K-LINE INSULATORS LIMITED** is registered to ISO 9001 Quality Systems.

## PERFORMANCE BENEFITS

The performance benefits of **KLI** InterPhase Spacer Insulators are listed below.

- Improves Reliability (by mitigating interruptions and outages due to conductor contact, flashovers or plant damage in all types of environments)
- Safety (light weight for handling and installation)
- Service Life (consistent performance over its service life)
- Life Cycle Cost (savings over ceramic insulators)

## APPLICATION

The quantity and placement of InterPhase Spacers in a span depends on the span length and the application. Contact your **KLI** Representative for application / placement instructions.

## CORE ROD

The core rod of the insulator is made of a high quality, epoxy resin, E-Glass fiberglass rod that has been specially formulated for electrical and mechanical applications.

## HOUSING

The housing (includes sheath and sheds) of the insulator is one piece, high temperature vulcanized, injection molded silicone rubber that is chemically bonded to the core rod. This ensures that the interface between the rubber and rod is impenetrable against moisture ingress. **KLI** uses its own proprietary silicone rubber formula in the manufacture of its insulators. The formulation has silicone rubber as the base polymer material with additives to enhance its performance in wet and contaminated environments.



**Crossing InterPhase Spacer**



**InterPhase Spacer installation from Helicopter using Barehand/Live Line work method**



**InterPhase Spacer installation**



**InterPhase Spacer installation using Hot Line Tools**

## DISTRIBUTION INTERPHASE SPACER – 15kV to 69kV

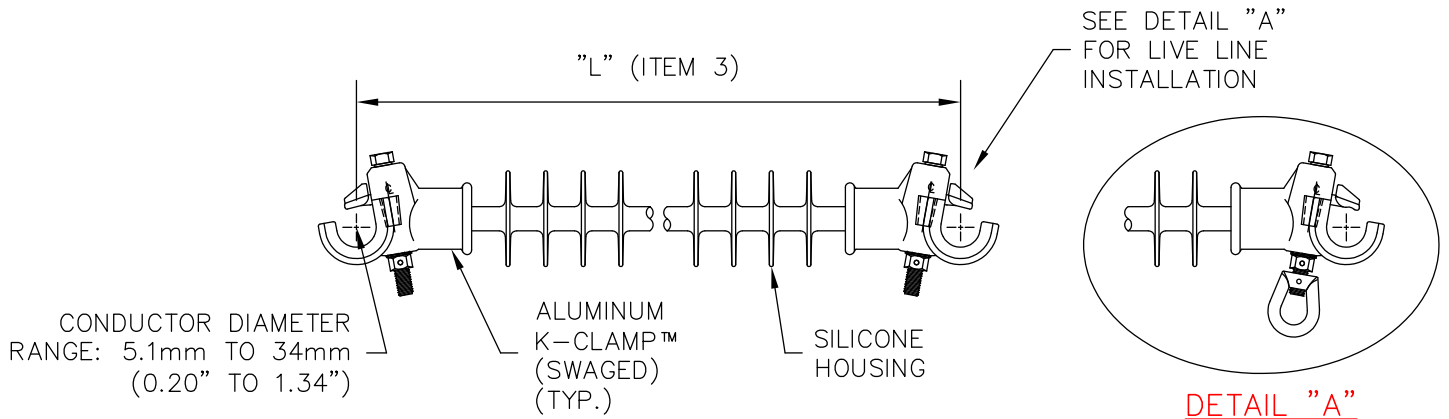

DESIGN WITH K-CLAMPS™

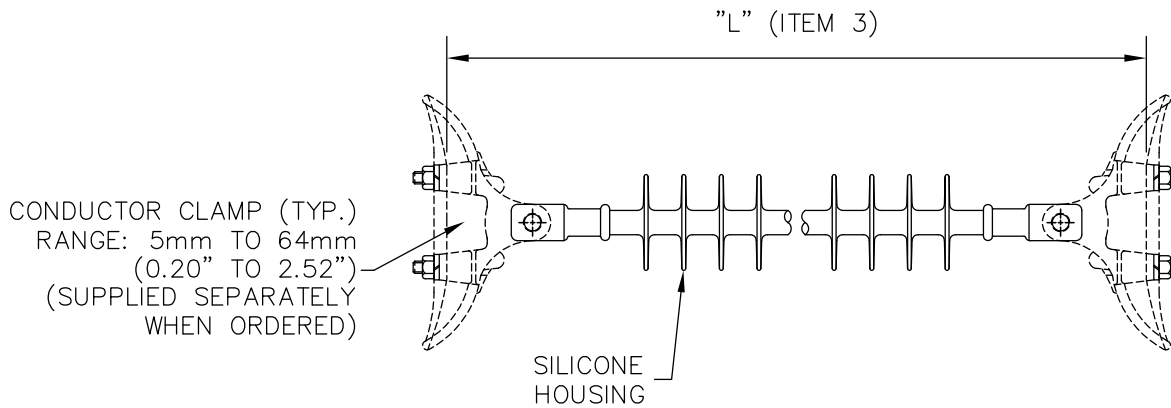

DESIGN WITH SUSPENSION CLAMPS

ITEM	SPECIFICATION	DATA	
1	OPERATING VOLTAGE (PHASE – PHASE)	kV	
2	MOUNTING ARRANGEMENT: 1) HORIZONTAL 2) VERTICAL		
3	LENGTH "L" (CONDUCTOR – CONDUCTOR)	mm	
4	CONDUCTOR DIAMETER (INCLUDING ARMOUR ROD IF APPLICABLE)	mm	
5	CONDUCTOR CLAMP: 1) SUSPENSION 2) K-CLAMP®		
6	POLLUTION LEVEL (IEC 60815)		
7	EYE NUT OPTION FOR LIVE LINE INSTALLATION (SEE DETAIL "A")	YES	NO

**NOTE:**

1. OTHER DESIGNS ARE AVAILABLE, PLEASE CONTACT KLI FOR DETAILS.
2. ARMOR ROD MAY BE REQUIRED

## SPECIAL APPLICATION DISTRIBUTION INTERPHASE SPACER – 15kV to 69kV

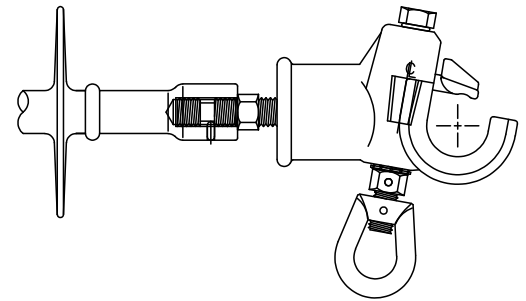

DETAIL "A"

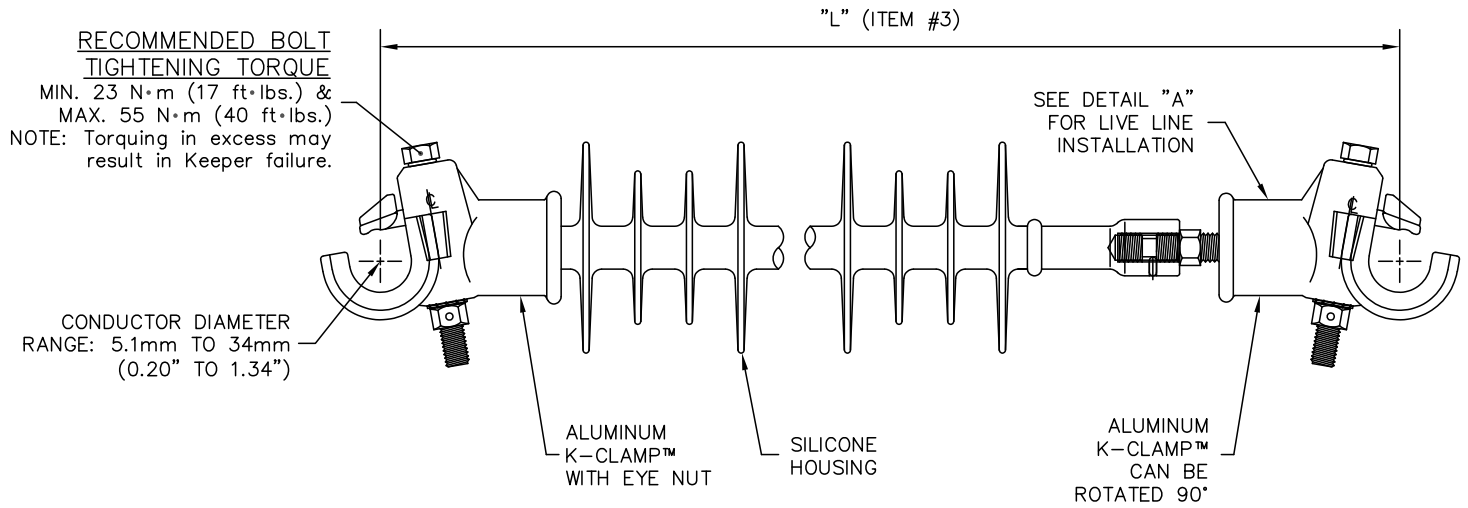

ITEM	SPECIFICATION	DATA	
1	OPERATING VOLTAGE (PHASE – PHASE)	kV	
2	MOUNTING ARRANGEMENT: 1) HORIZONTAL 2) VERTICAL		
3	LENGTH "L" (CONDUCTOR – CONDUCTOR)	mm	
4	CONDUCTOR DIAMETER (INCLUDING ARMOUR ROD IF APPLICABLE)	mm	
5	CONDUCTOR CLAMP: 1) ADJUSTABLE K-CLAMP®		
6	POLLUTION LEVEL (IEC 60815)		
7	EYE NUT OPTION FOR LIVE LINE INSTALLATION (SEE DETAIL "A")	YES	NO

**NOTE:**

1. OTHER DESIGNS ARE AVAILABLE, PLEASE CONTACT KLI FOR DETAILS.
2. THIS DESIGN IS INTENDED FOR SHORT SPANS AND TO ASSIST IN CONTROLLING LOW SEVERITY CONDUCTOR MOTION.
3. ARMOR ROD MAY BE REQUIRED.

## TRANSMISSION INTERPHASE SPACER – 69kV to 400kV

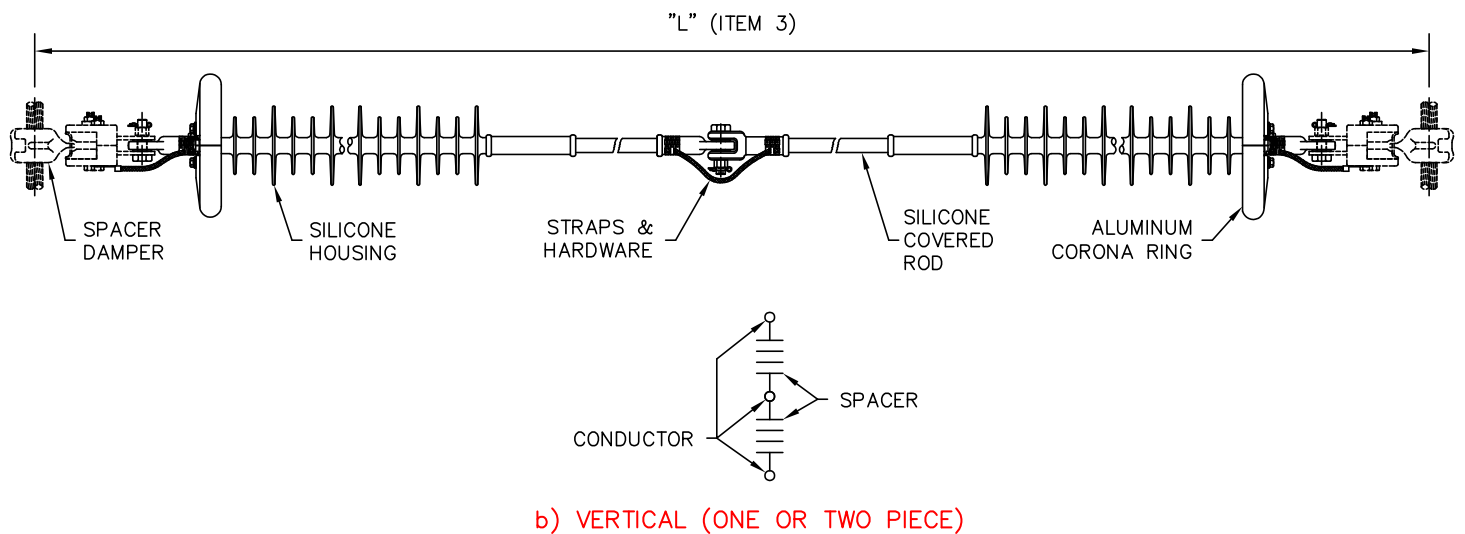
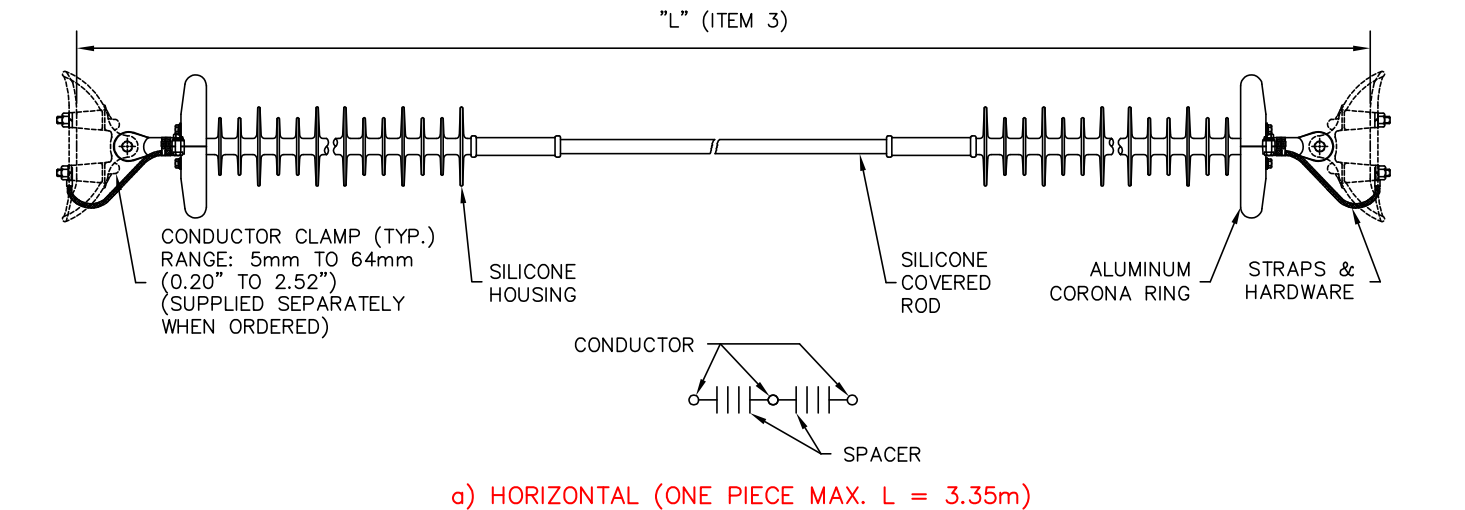

ITEM	SPECIFICATION	DATA
1	OPERATING VOLTAGE (PHASE – PHASE)	kV
2	MOUNTING ARRANGEMENT: 1) HORIZONTAL 2) VERTICAL	
3	LENGTH "L" (CONDUCTOR – CONDUCTOR)	mm
4	CONDUCTOR DIAMETER (INCLUDING ARMOUR ROD IF APPLICABLE)	mm
5	CONDUCTOR CLAMP: 1) SUSPENSION	
6	POLLUTION LEVEL (IEC 60815)	

**NOTE:**

1. OTHER DESIGNS ARE AVAILABLE, PLEASE CONTACT KLI FOR DETAILS.
2. ARMOR ROD MAY BE REQUIRE



**K-LINE INSULATORS LIMITED**

50 Passmore Avenue, Toronto, Ontario, Canada M1V 4T1

• Tel.: (416) 292-2008 • E-Mail: [insulators@k-line.net](mailto:insulators@k-line.net) • Web Page: [www.k-line.net](http://www.k-line.net)



**K-LINE INSULATORS LIMITED**  
TORONTO, ONTARIO, CANADA

# Catalogue D-RS

## DISTRIBUTION SILICONE INSULATORS

### *Riser Support* *15 kV to 69 kV*



ISO9001  
SAI GLOBAL  
FILE No. 000117

# Distribution Silicone Insulators

## Riser Support

On distribution overhead lines there are numerous tap-offs from the main line to provide connections to equipment (e.g., transformers, switches, fuses, underground cables, etc.) or lines (e.g., services, junctions, etc.). Normally leads are used to connect the equipment or line to the main line. These leads can be long and difficult or hazardous to operate. The use of riser support insulators can provide a safe and economical support for these leads.

**K-LINE INSULATORS LIMITED (KLI)** silicone riser support insulators are manufactured and tested to world-class polymer insulator standards, CSA, ANSI and IEC.

**K-LINE INSULATORS LIMITED** is registered to ISO 9001 Quality Systems.

### APPLICATION

Distribution riser support insulators are used on distribution lines operating at or below 69 kV. These insulators are installed on metal, concrete or wooden structures, standoff brackets and cross arms to hold and insulate conductor leads.

### CORE ROD

The core rod of the insulator is made of a high quality, epoxy resin, E-Glass fiberglass rod that has been specially formulated for electrical and mechanical applications.

### HOUSING

The housing (includes sheath and sheds) of the insulator is one piece, high temperature vulcanized, injection molded silicone rubber that is chemically bonded to the core rod. This ensures that the interface between the rubber and rod is impenetrable against moisture ingress. **KLI** uses its own proprietary silicone rubber formula in the manufacture of its insulators. The formulation has silicone rubber as the base polymer material with additives to enhance its performance in wet and contaminated environments.

### FITTINGS

The riser insulator comes standard with a clamp to hold the conductor and a threaded base for mounting to apparatus.

#### **Conductor Clamp**

The clamp is an aluminum clamp that can accommodate copper or aluminum conductors 5.0mm to 23.5mm (0.20" to 0.95").

#### **Threaded Base**

The base is typically threaded for 5/8"-11, 3/4"-10, M16x2, or M20x2.5 galvanized bolt.

For other special clamp features or base threads please contact **KLI**.

# DISTRIBUTION RISER SUPPORT INSULATORS

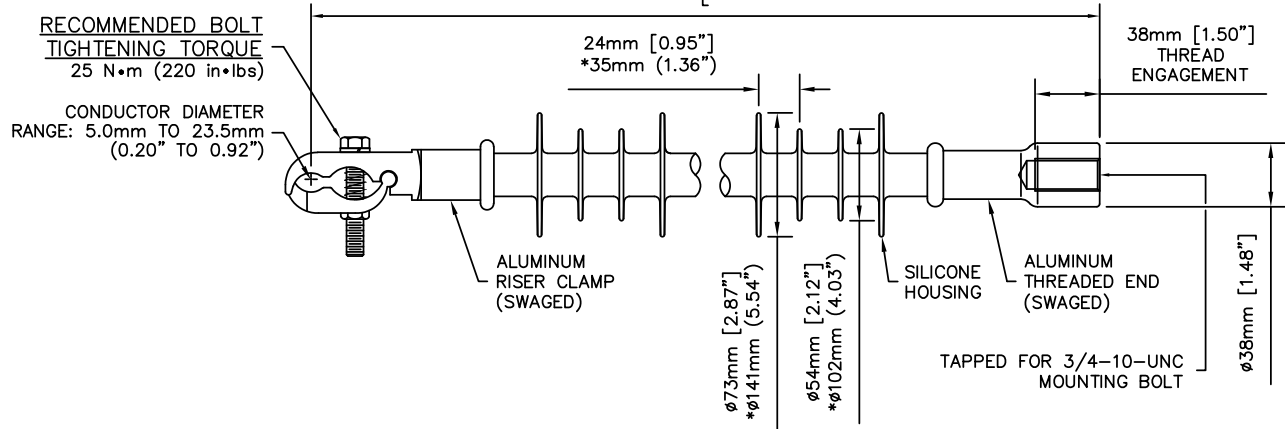

KL15ARSIU, KL28ARSIU & \*KL69HRSIU16

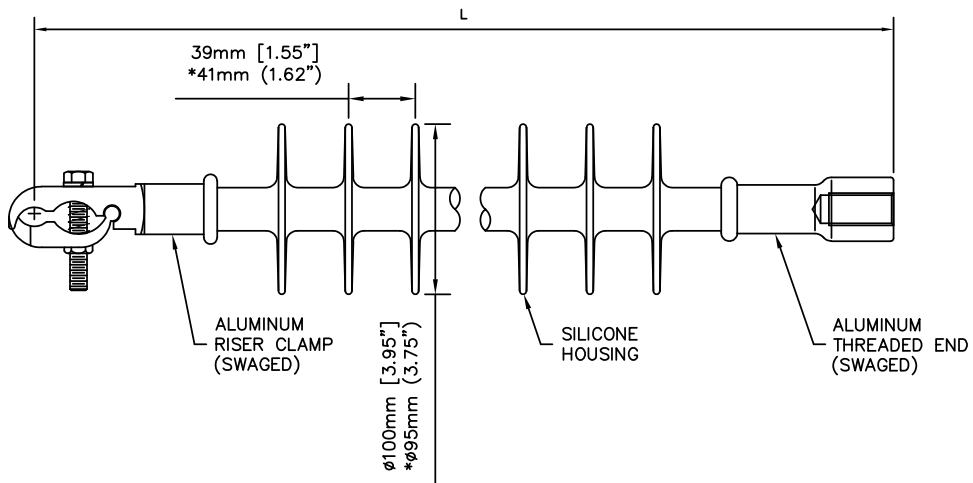

\*KL35SRSIU & KL46SRSIU

## TECHNICAL DATA

SPECIFICATIONS	UNIT	CATALOGUE NUMBER**					
		KL15ARSIU	KL28ARSIU	KL35SRSIU	KL46SRSIU	KL69HRSIU16	
Voltage Class	kV	15	28	35	46	69	
Section Length "L"	mm (in)	370 (14.6)	480 (18.9)	534 (21.0)	600 (23.6)	766 (30.2)	
Dry Arcing Distance	mm (in)	193 (7.6)	290 (11.4)	348 (13.7)	419 (16.5)	627 (24.7)	
Leakage Distance	mm (in)	384 (15.1)	590 (23.2)	750 (29.5)	988 (38.9)	1798 (70.8)	
Low-Frequency Flashover	Dry	kV	100	135	155	180	260
	Wet	kV	75	100	145	150	245
Critical Impulse Flashover (Pos.)	kV	150	225	265	300	425	
Specified Cantilever Load (SCL)	kN (lb)	1.7 (381)	1.2 (270)	1.1 (237)	0.9 (205)	0.7 (155)	
Max. Design Cantilever Load (MDCL)	kN (lb)	0.42 (95)	0.27 (60)	0.20 (45)	0.15 (35)	0.09 (20)	
Approx. Weight	kg (lb)	0.7 (1.5)	0.9 (1.9)	2.1 (4.7)	2.2 (4.8)	2.3 (5.1)	
Standard Packaging	-	18	18	12	12	6	

\*\* Options: For 5/8" tapped hole add 'X', for M16 add 'M16', or for M20 add 'M20' and for tin-plated clamp add 'D' to the catalogue number.



### K-LINE INSULATORS LIMITED

50 Passmore Avenue, Toronto, Ontario, Canada M1V 4T1

• Tel.: (416) 292-2008 • E-Mail: [insulators@k-line.net](mailto:insulators@k-line.net) • Web Page: [www.k-line.net](http://www.k-line.net)

# Standoff Brackets for Line Post Insulators

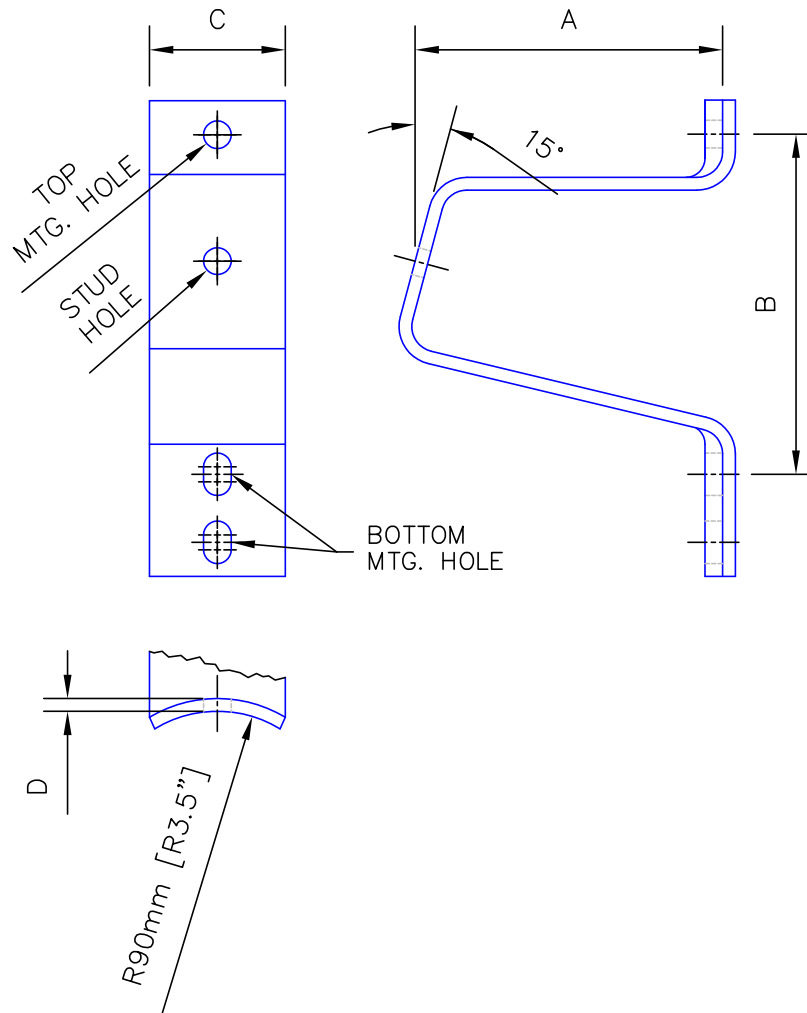

**Material: Galvanized Steel**

KLI PART No.	A mm (in)	B mm (in)	C mm (in)	D mm (in)	STUD HOLE in	TOP MTG. HOLE mm (in)	BOTTOM MTG. SLOT in	No. OF BOTTOM MTG. HOLE
KLOP149	76 (3)	255 (10)	102 (4)	10 (0.38)	13/16	21 (0.81)	0.81x1.25	1
KLOP-HWBK08	76 (3)	255/305 (10/12)	102 (4)	10 (0.38)	13/16	21 (0.81)	0.81x1.25	2
KLMP-BK03	76 (3)	255/305 (10/12)	127 (5)	13 (0.50)	15/16	21 (0.81)	0.81x3.25	2
KLOP056	230 (9)	255 (10)	102 (4)	10 (0.38)	13/16	21 (0.81)	0.81x1.25	1
KLOP056-1	230 (9)	255/305 (10/12)	102 (4)	10 (0.38)	13/16	21 (0.81)	0.81x1.25	2
KLMP-BK02	230 (9)	305 (12)	127 (5)	13 (0.50)	15/16	23 (0.90)	0.90x1.25	1
KLOP-GB10-18	457 (18)	255 (10)	102 (4)	10 (0.38)	13/16	21 (0.81)	0.81x1.25	1



**K-LINE INSULATORS LIMITED**

50 Passmore Avenue, Toronto, Ontario, Canada M1V 4T1

• Tel.: (416) 292-2008 • E-Mail: [insulators@k-line.net](mailto:insulators@k-line.net) • Web Page: [www.k-line.net](http://www.k-line.net)

# Trunnion Clamp for Line Post Insulators

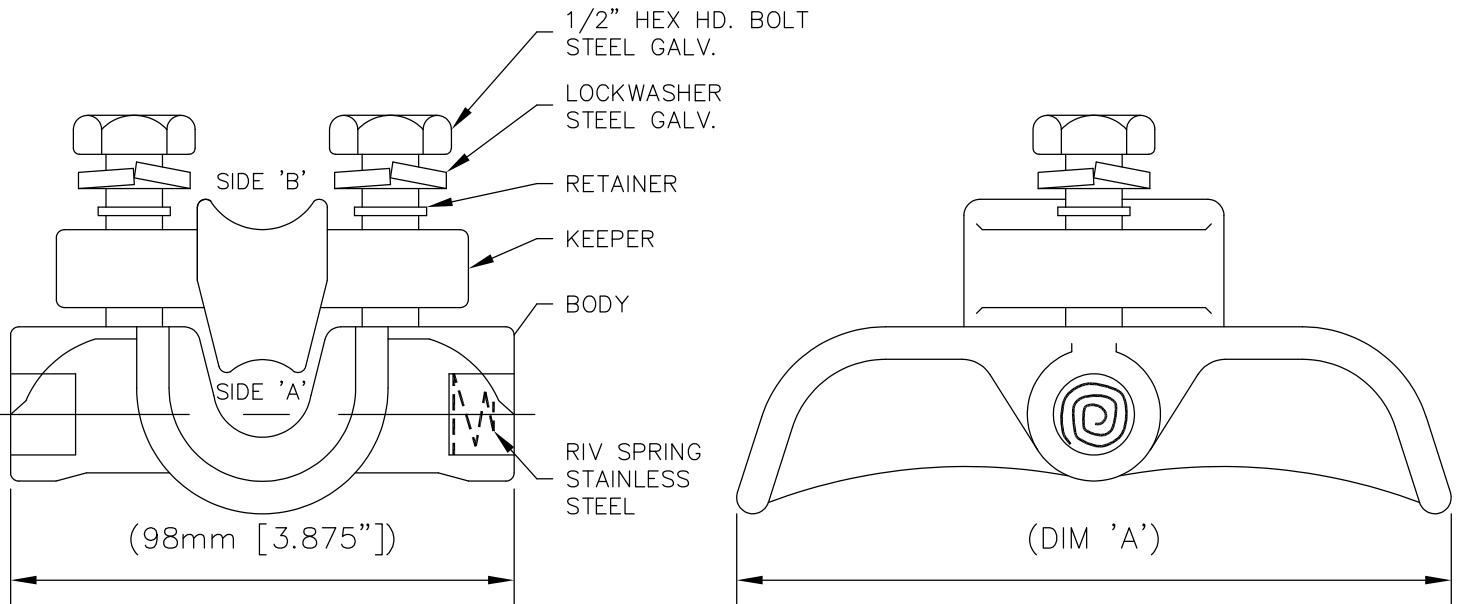

TABLE

PART No.	MATERIAL (BODY & KEEPER)	CONDUCTOR RANGE		DIM. A mm (in)
		SIDE 'A' mm (in)	SIDE 'B' mm (in)	
KLOP026	ALUMINUM	6.4–19.1 (0.25–0.75)	15.7–27.2 (0.62–1.07)	140 (5.50)
KLOP026I	MALLEABLE IRON GALVANIZED	6.4–19.1 (0.25–0.75)	15.7–27.2 (0.62–1.07)	140 (5.50)
KLOP173	ALUMINUM	25.4–31.8 (1.00–1.25)	32.0–38.1 (1.26–1.50)	133 (5.25)
KLOP059	ALUMINUM	38.1–44.5 (1.5–1.75)	44.7–50.8 (1.76–2.00)	133 (5.25)



**K-LINE INSULATORS LIMITED**

50 Passmore Avenue, Toronto, Ontario, Canada M1V 4T1

• Tel.: (416) 292-2008 • E-Mail: [insulators@k-line.net](mailto:insulators@k-line.net) • Web Page: [www.k-line.net](http://www.k-line.net)

# Studs for Line Post Insulators

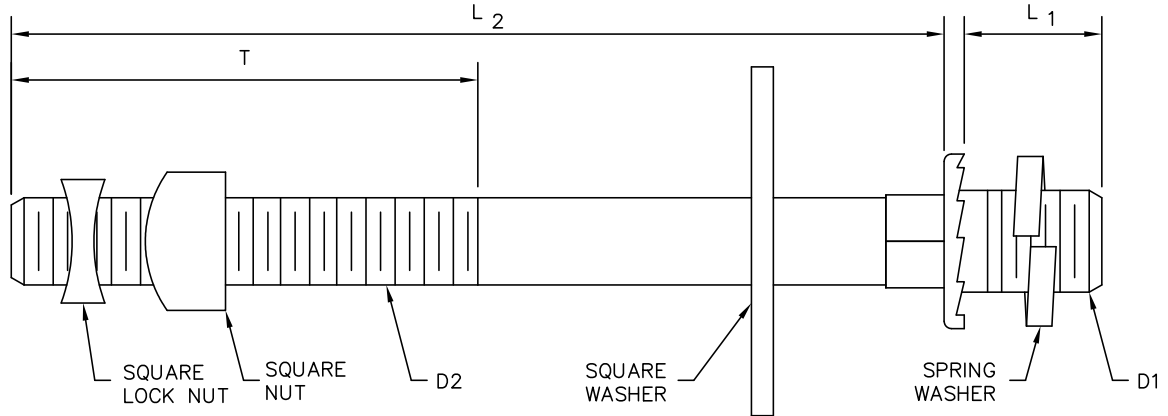

## LONG STUD

**TABLE 1**

KLI Part No.	D1	D2	L <sub>1</sub>	L <sub>2</sub>	T	Washer Size
KLOP032B	3/4"-10UNC	5/8"-11 UNC	1"	6"	4"	2-1/4" x 2-1/4"
KLOP032	3/4"-10 UNC	5/8"-11 UNC	1"	6"	2-1/2"	2" x 2"
KLOP153	3/4"-10 UNC	3/4"-10 UNC	1"	7-1/2"	4"	2-1/4" x 2-1/4"
KLOP032E	3/4"-10 UNC	3/4"-10 UNC	1"	6"	5"	3" x 3"
KLOP032C	3/4"-10 UNC	3/4"-10 UNC	1"	7-1/2"	4"	3" x 3"
KLOP-HWBP03	7/8"-9 UNC	3/4"-10 UNC	1-1/4"	7-1/2"	4"	3" x 3"
KLOP032D	7/8"-9 UNC	7/8"-9 UNC	1-1/4"	8"	4"	3" x 3"

Note: Item KLOP032 has a hex nylock nut.

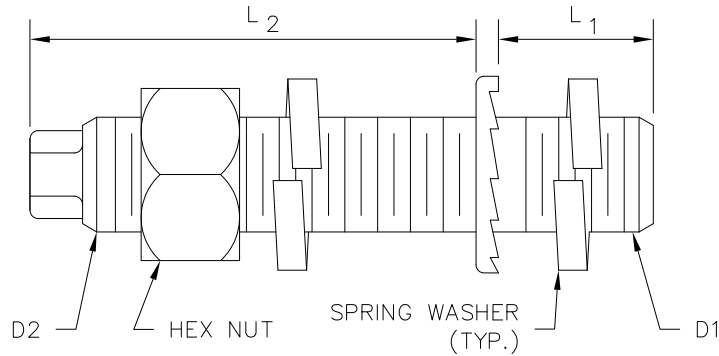

## SHORT STUD

**TABLE 2**

KLI Part No.	D1	D2	L <sub>1</sub>	L <sub>2</sub>
KLOP027	3/4"-10 UNC	3/4"-10 UNC	1"	2-1/4"
KLOP027A	3/4"-10 UNC	3/4"-10 UNC	1"	2-1/2"
KLOP027B	7/8"-9 UNC	7/8"-9 UNC	1-1/4"	3-1/2"

Material: Steel, Hot Dipped Galvanized.

Dimension: L<sub>1</sub>, L<sub>2</sub> & T are approximate.



## K-LINE INSULATORS LIMITED

50 Passmore Avenue, Toronto, Ontario, Canada M1V 4T1

• Tel.: (416) 292-2008 • E-Mail: [insulators@k-line.net](mailto:insulators@k-line.net) • Web Page: [www.k-line.net](http://www.k-line.net)



K-LINE INSULATORS LIMITED  
TORONTO, ONTARIO, CANADA

# Catalogue: Hardware

## "SCORPION" Neutral Conductor Clamp

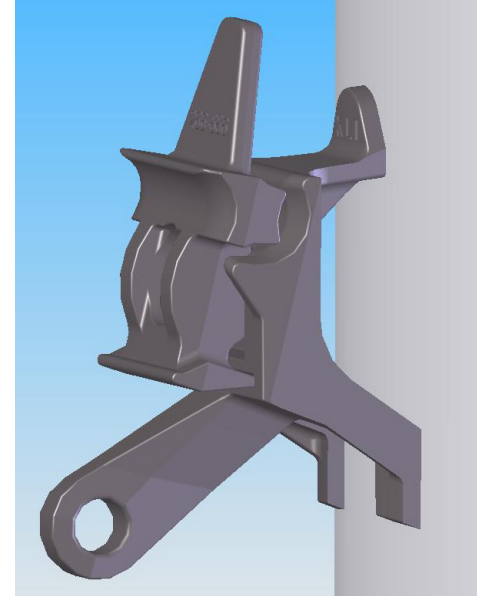
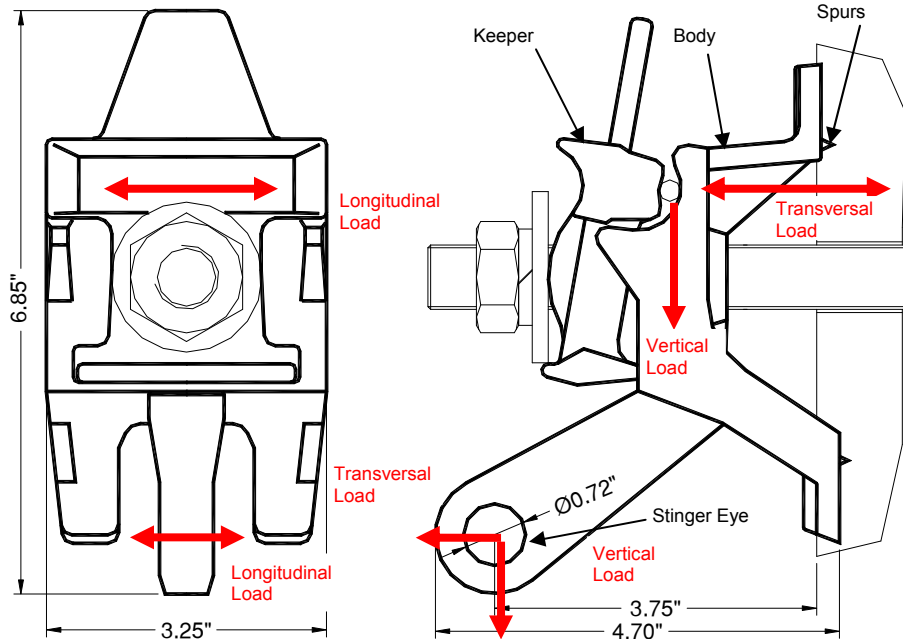

The "SCORPION" Neutral Conductor Clamp was developed specifically to address the expressed needs of Customers using a wide range of Neutral Conductor sizes, including large diameter conductors. The Galvanized Iron "SCORPION" was designed to accommodate Conductor sizes from #4 AWG to 715 kcmil. The Stinger Eye has a 0.72" diameter hole for temporary support of Conductor Stringing Rollers during line construction. The Stinger Eye also serves as a permanent attachment point for an Overhead Secondary Service Tap. The "SCORPION" is supplied with a Round Washer and Lock Washer, Spurs or no Spurs and installed with Customer supplied  $\frac{3}{4}$ " Bolt Hardware.

### FEATURES:

**Material:** Ductile Iron, Hot Dip Galvanized.

**Mounting Spurs** for Wood Pole. **No Spurs** for Steel, Concrete, and Composite Poles.

**Conductor Range:** 0.20" (#4 AWG) to 0.98" (715 kcmil AAC)

**Maximum Line Angle:** 15°

**Stinger Eye:** For the attachment of a Stringing Roller during conductor installation or Secondary Service Tap.

**Pole Mounting:** The SCORPION is shipped with one  $\frac{3}{4}$ " flat round washer (max. 2" OD and min. 0.14" thick) and one  $\frac{3}{4}$ " lock washer. The bolt and nut are customer supplied at appropriate length. The installation torque for the  $\frac{3}{4}$ "-10 UNC bolt and nut is 130 ft•lbs.



ISO9001  
SAI GLOBAL  
FILE No. 000117

## CLAMPS

Catalogue Number	Mounting Spurs	Body Tapped	Weight per Unit	Standard Packaging
KLOP-HWCP08-A	Yes	3/4"-10 UNC Bolt	4.5 lbs.	12 Units per box
KLOP-HWCP08-B	No			

## MAXIMUM DESIGN LOADS

	Maximum Design Loads	kN (lbs)
Loads supported by <b>Neutral Clamp (Body and Keeper)</b>	Maximum Design Slip Load (MDSL) for a 0.850" dia. conductor	5.5 (1,250)
	Maximum Design Transversal Load (MDTL) on Keeper	10.0 (2,250)
	Maximum Design Transversal Load (MDTL) on Body	13.0 (2,900)
	Maximum Design Vertical Load (MDVL)	13.0 (2,900)
Loads supported by <b>Neutral Clamp Stinger Eye</b>	Maximum Design Transversal Load (MDTL)	11.0 (2,500)
	Maximum Design Vertical Load (MDVL)	12.5 (2,800)

### NOTES:

The MAXIMUM DESIGN LOADS are allowable loads

The Loads are independent



### **K-LINE INSULATORS LIMITED**

50 Passmore Avenue, Toronto, Ontario, Canada M1V 4T1

• Tel.: (416) 292-2008 • E-Mail: [insulators@k-line.net](mailto:insulators@k-line.net) • Web Page: [www.k-line.net](http://www.k-line.net)



**K-LINE INSULATORS LIMITED**  
TORONTO, ONTARIO, CANADA

# Catalogue MB-PT

## **Single Circuit** *Pole Top Framing Assembly*

---



ISO9001  
SAI GLOBAL  
FILE No. 000117

# Single Circuit Pole Top Framing Assembly

The ultimate in labour savings and convenience is provided by **K-Line Insulators Limited's** single circuit pole-top framing assembly. The assembly comes complete in kit form with mounting bracket, polymer line post insulators, trunnion clamps or K-CLAMP® and insulator mounting studs. Install with two bolts and the structure is ready to go.

This assembly provides increased clearance for work methods, wildlife outages and clearance above ground.

The hot dip galvanized steel brackets come with predrilled holes for mounting of riser support insulators and a grounding lug. The insulators are of silicone, the ultimate in polymer line post insulators for maintenance-free operation.

## Single Circuit Pole Top Framing Assembly

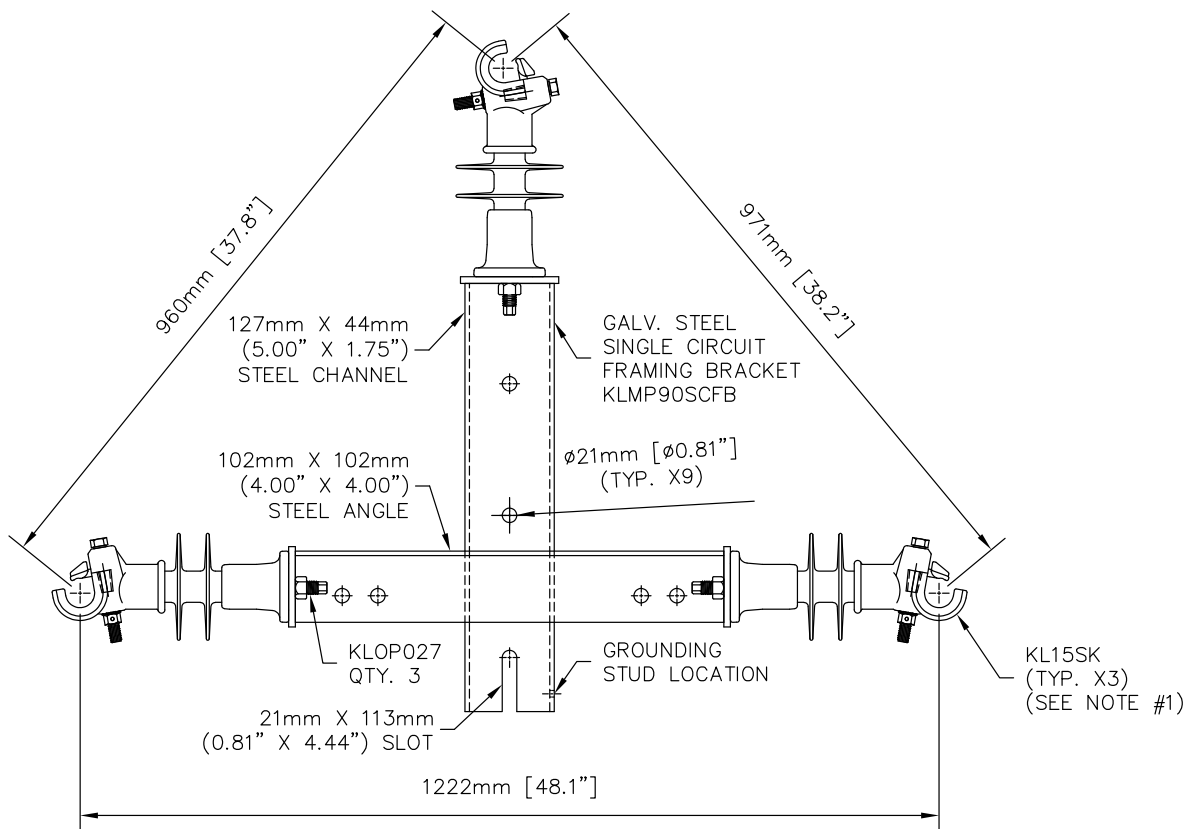

**NOTE:**

1. Shipped unassembled with various insulator designs. Please contact **K-Line** Engineering for more information.



**K-LINE INSULATORS LIMITED**

50 Passmore Avenue, Toronto, Ontario, Canada M1V 4T1

• Tel.: (416) 292-2008 • E-Mail: [insulators@k-line.net](mailto:insulators@k-line.net) • Web Page: [www.k-line.net](http://www.k-line.net)



**K-LINE INSULATORS LIMITED**  
TORONTO, ONTARIO, CANADA

# Catalogue D-TIF

## **Totally Insulated Framing System (TIF™)** **3-Phase TIF™ Tri-Frame - Distribution** **15kV - 69kV (Patent No.: US 9,685,772)**



ISO9001  
SAI GLOBAL  
FILE No. 000117

# 3-Phase TIF™ Tri-Frame - Distribution

## Totally Insulated Framing System (Patent No.: US 9,685,772)

Generally Insulators are used to support electrical conductors on Overhead Distribution and Sub-Transmission systems to prevent line to ground contact. Conductors may be attached to Deadend/Suspension Insulators and suspended from Crossarms or supported on Line Post/Pin Insulators on Crossarms or Side Post Brackets. Conventional Crossarms have service life limitations due to wood rot, steel corrosion or fiber reinforced polymer (FRP) deterioration.

**K-LINE INSULATORS LIMITED (KLI)** is introducing the Totally Insulated Framing (TIF™) Tri-Frame design for Distribution Lines for nominal voltages up to and including 69 kV. This innovative design reduces many common concerns and difficulties encountered with wood, steel or fiberglass Crossarms.

**K-LINE INSULATORS LIMITED (KLI)** Totally Insulated Framing (TIF™) Systems offer alternative line designs that increase service life, reduce installation labour costs, enhance system reliability and improves safety during installation. **KLI TIF™** Systems are a new, cost effective approach for Line Design, Construction, Maintenance and “Hardening” of Distribution and Sub-Transmission Systems.

The TIF™ Tri-Frame configuration for Distribution or Sub-Transmission Lines offers an integrated one-piece framing concept that forms a compact three phase framing. TIF™ Tri-Frames are delivered fully assembled in a one piece frame configuration for rapid installation by simply bolting the TIF™ Tri-Frame assembly to the pole. Patented K-CLAMP® or conventional Line Post End Fittings can be supplied with TIF™ Tri-Frame designs. The TIF™ Tri-Frame provides required horizontal and vertical conductor spacing and clearances and is an alternative to typical single circuit Crossarm or Armless Construction Standards. TIF™ offers significant cost savings over conventional line construction practices due to reduced labour for installation of the TIF™ Tri-Frame. Installation is a simple matter of Bolting the TIF™ Tri-Frame to the Pole with two Bolts compared to conventional line design and construction practices which normally require installation of Crossarms/Braces or Pole Top/Side Post Brackets, Insulator Pins/Studs, Insulators and related hardware.

### **Summary of TIF™ Feature/Advantages/Benefits:**

- TIF™ Tri-Frame offers improved safety in application. Rapid installation reduces Lineman exposure time in energized work environment
- Improved system reliability with integrated KLI proprietary Silicone Rubber Insulators
- Corrosion resistant Aluminum Alloy End Fittings and Frame
- TIF™ eliminates Crossarm life limitations due to rot, hidden corrosion and fiberglass deterioration
- TIF™ is lightweight and can be transported by line crews into areas difficult to access and erected in place without heavy lifting equipment
- TIF™ avoids vandalism associated with glass and porcelain insulators
- Improved aesthetics and compact triangular appearance
- TIF™ Tri-Frame Insulator configuration discourages “roosting” thus minimizing the probability of wildlife contact issues.

## 3-Phase TIF™ - Distribution (Patent No.: US 9,685,772)

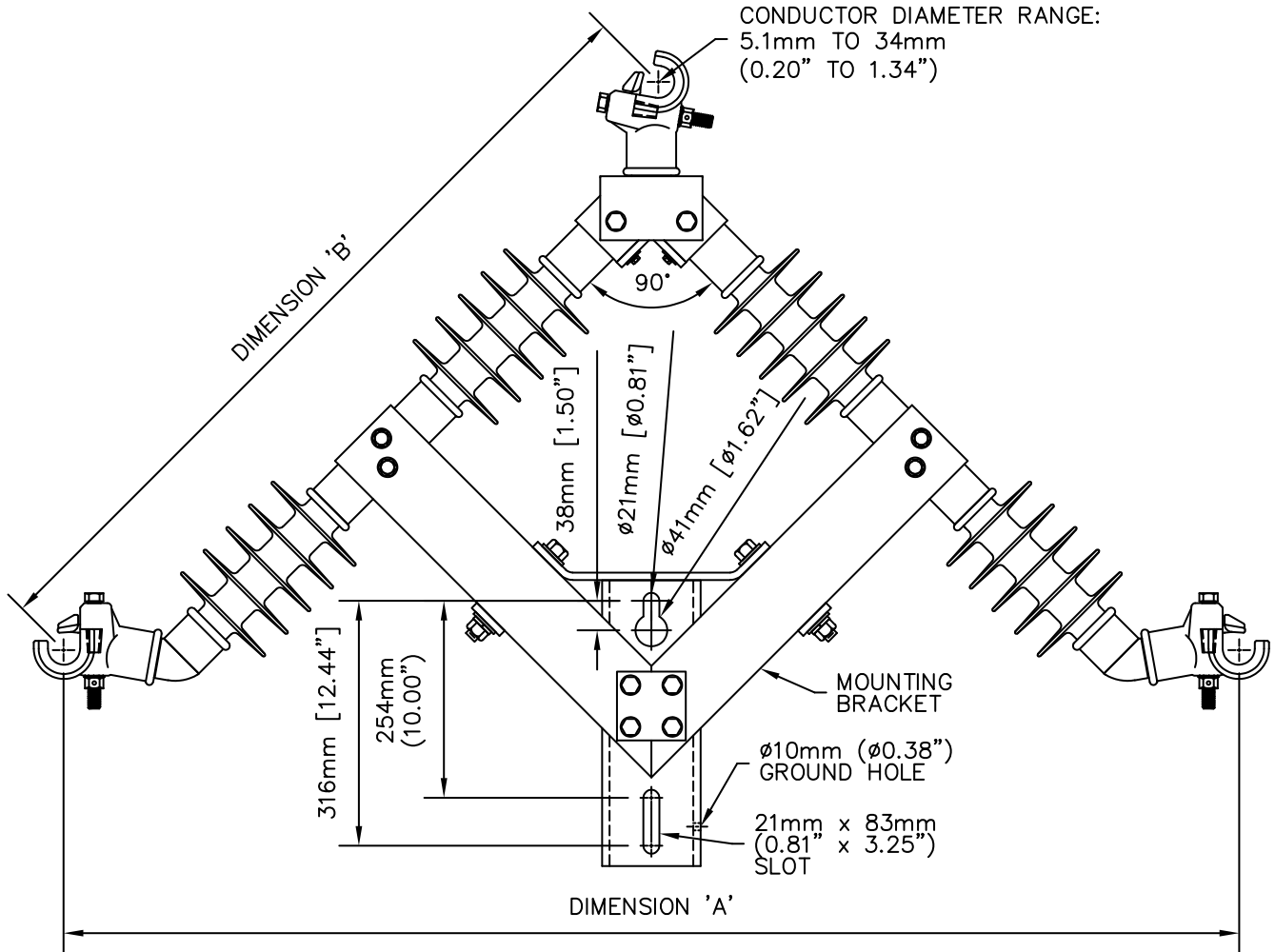

### TECHNICAL DATA

SPECIFICATIONS	UNITS	CATALOGUE NUMBER			
		KL35TIF_	KL46TIF_	KL69PTIF_	KL69P1TIF_
Voltage Class	kV	35	46	46	69
Leakage	mm (in)	660 (26)	860 (34)	1170 (46)	1525 (60)
Critical Impulse Flashover (Pos.)	kV	195	240	300	360
Low-Frequency Wet Flashover	kV	85	115	150	190*
Dimension 'A' (Approx.)	mm (in)	1520 (60)	1730 (68)	1930 (76)	2235 (88)
Dimension 'B' (Approx.)	mm (in)	1060 (42)	1210 (48)	1350 (53)	1570 (62)
Vertical Design Load **	kN (lbs)	6.0 (1350)	6.0 (1350)	6.0 (1350)	5.5 (1240)
Transverse Design Load **	kN (lbs)	5.5 (1240)	5.5 (1240)	5.5 (1240)	5.5 (1240)
Weight (Approx.)	kg (lbs)	37.2 (82.0)	40.3 (88.9)	44.0 (96.9)	50.5 (111.0)

\*The value shown is as per CSA.

\*\*Individual conductor loads

**NOTE:** The selection of the appropriate TIF™ design model depends on the minimum insulation voltage design required. Additionally, the minimum phase spacing requirement must also be considered in selecting the TIF™ design model.

#### Ordering Information

The TIF™ Framing Assemblies are available with K-CLAMPS® or Horizontal/Vertical Trunnions. Add suffix **K** for K-CLAMP® or **T** for Horizontal & **V** for Vertical Trunnions. Conductor Clamps are ordered separately.

## 3-Phase TIF™ - Distribution Field Trial (Patent No.: US 9,685,772)



### K-LINE INSULATORS LIMITED

50 Passmore Avenue, Toronto, Ontario, Canada M1V 4T1

• Tel.: (416) 292-2008 • E-Mail: [insulators@k-line.net](mailto:insulators@k-line.net) • Web Page: [www.k-line.net](http://www.k-line.net)



**K-LINE INSULATORS LIMITED**  
TORONTO, ONTARIO, CANADA

# Catalogue T-TIF

## **Totally Insulated Framing System (TIF™)** **TIF™ - Transmission (H-Frame)** **69kV - 230kV (Patent No.: US 9,685,772)**



ISO9001  
SAI GLOBAL  
FILE No. 000117

# TIF™ - Transmission (H-Frame) (Patent No.: US 9,685,772)

## Totally Insulated Framing System

The new **K-LINE INSULATORS LIMITED (KLI)** Totally Insulated Framing Systems for Transmission Lines (TIF™) improves conventional H-Frame Pole and Crossarm construction by using KLI Insulators assembled in innovative and new configurations to perform the Crossarm function.

Typically, Treated Lumber, Steel or Composite Crossarms are used to support Insulators/Conductors on Overhead Transmission Line H-Frame structures. Conventional Crossarms have service life limitations due to wood rot, steel corrosion or fiber reinforced polymer (FRP) deterioration.

**KLI** is introducing TIF™ designs for Transmission Lines for nominal voltages up to and including 230 kV. The innovative Silicone InsulArm of TIF™, replaces conventional Crossarms and addresses service life limitations and concerns with standard Crossarm materials. Field proven, **KLI** Transmission Post Insulators, manufactured to KLI's high standards are assembled to form the Crossarm in a variety of configurations.

Flexibility is one special characteristic of the TIF™ design for Transmission. The Silicone InsulArm is an assembled part and can be delivered in Modular Components or factory assembled as One-Piece. In areas with difficult access, Line Crews can easily transport lightweight InsulArm modules for on-site assembly of the Silicone InsulArm. Heavy transport or high capacity moving and material handling equipment is not required. Another advantage of the modular Silicone InsulArm is simple replacement of individual components in place without having to remove the assembled Silicone InsulArm.

Installation simplicity is an important feature of the TIF™ H-Frame InsulArm system. If acquired as One-Piece, the H-Frame InsulArm is simply and safely hoisted to position and quickly bolted in position with two machine bolts per pole. Installation time and cost is minimized as the TIF™ Silicone InsulArm is in place and ready for attachment of Conductor Suspension Hardware direct to the TIF™ Silicone InsulArm.

Integrated Conductor Hardware attachment points on the Silicone InsulArm facilitate positioning of the Conductor Hardware/Conductor direct to the InsulArm eliminating the need for Suspension Insulators. Vertical Ground Clearance is increased. This feature allows the option of using shorter poles or increasing line operating current. Fixed positioning of Conductors on the TIF™ InsulArm eliminate suspension insulator swing under ice and wind conditions and ROW width requirements may be reduced.

For transmission line framings, optional "Brace" Insulators are available to increase load carrying capacity up to 80% depending on the angle between the Horizontal InsulArm and the supporting Brace Insulator. Standard Conductor Suspension Clamps can be used for line attachment. The H-Frame system is available for common transmission line voltages but can also be customized.

TIF™ Silicone InsulArm systems for H-Frame construction offer innovative, cost effective solutions for Crossarm life limitation concerns while maintaining required horizontal and vertical conductor spacing and clearances based on the voltage of the application.

An example for technical data is Catalogue No. KL115TIF1010 with 10' Pole & Conductor Spacing:

SPECIFICATIONS	UNITS	CATALOGUE NUMBER
		<b>KL115TIF1010</b>
Voltage Class	kV	115
Leakage Distance	mm (in)	2583 (101.7)
Critical Impulse Flashover (Pos.)	kV	590
Low-Frequency Wet Flashover	kV	330
DIMENSION 'A'	mm (in)	3136 (123.4)
DIMENSION 'D'	mm (in)	2898 (114.1)
Max. Design Vertical Load	kN (lbs)	9.1 (2042)

## TIF™ -Transmission Spacing Options: (Patent No.: US 9,685,772)

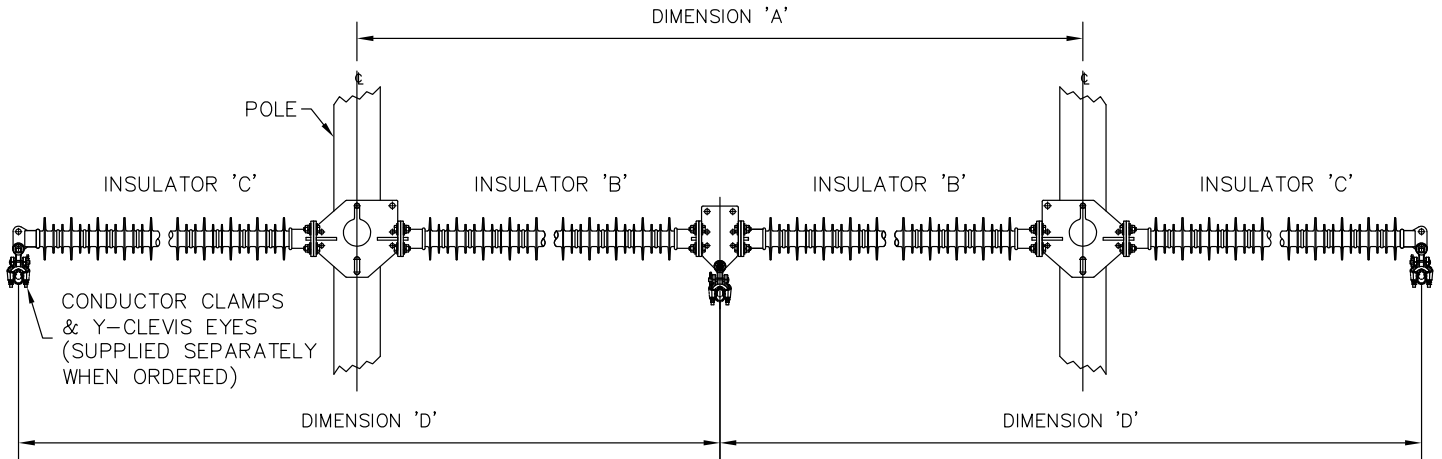

### TIF™ -TRANSMISSION SPACING OPTIONS

K-Line Cat. No.	System Voltage (kV)	Approx. Pole Spacing Dimension 'A' mm (ft)	Insulator/s 'B'	Insulator/s 'C'	Conductor Spacing Dimension 'D' mm (ft)	Max. Design Vertical Load kN (lbs) (See Notes)	Approx Weight kg (lb)
KL69TIF0908	69	2640 (8.6)	19 sheds	19 sheds	2527 (8.3)	10.5 (2375)	127 (280)
KL115TIF1010	115	3136 (10.3)	25 sheds	22 sheds	2898 (9.5)	9.1 (2042)	137 (302)
KL138TIF1211	138	3631 (11.9)	31 sheds	28 sheds	3394 (11.1)	6.9 (1550)	150 (330)
KL161TIF1413B	161	4127 (13.5)	37 sheds	34 sheds	3890 (12.7)	43.9 (9865)	223 (492)
KL230TIF2018B	230	6088 (20.0)	28 sheds x 2	22 sheds x 2	5517 (18.1)	44.6 (10,025)	306 (675)

### BUILDING A TRANSMISSION TIF™ SYSTEM

1. Insulators 'B' in the TIF™-TRANSMISSION SPACING OPTIONS Table are selected to match existing pole spacing (Dimension 'A') or for new lines, Insulators 'B' may be selected so that pole spacing (Dimension 'A') is reduced due to TIF™ eliminating insulator swing.
2. Insulators 'C' can then be selected for a reduced and optimized ROW since TIF™ eliminates insulator swing, while still maintaining required conductor spacing Dimension 'D'.
3. Technical Data is based on Insulator/s 'C' and can be found by referencing the **KLI** catalogue Transmission Line Post section for the Insulator(s) 'C' selected. The correlation between No. of sheds and the catalogue part number is explained in that section.

#### NOTES:

1. For higher loads bracing may be required. Please contact **K-Line** Engineering.
2. For other combinations and system voltages that are not covered in the table above. Please contact KLI Engineering.
3. The Max. Design Vertical Load (MDVL) is the allowable load. The Ultimate Load is two times the MDVL.

#### ORDERING INFORMATION

For ordering, the catalog number of the specific insulator is formulated as shown below:

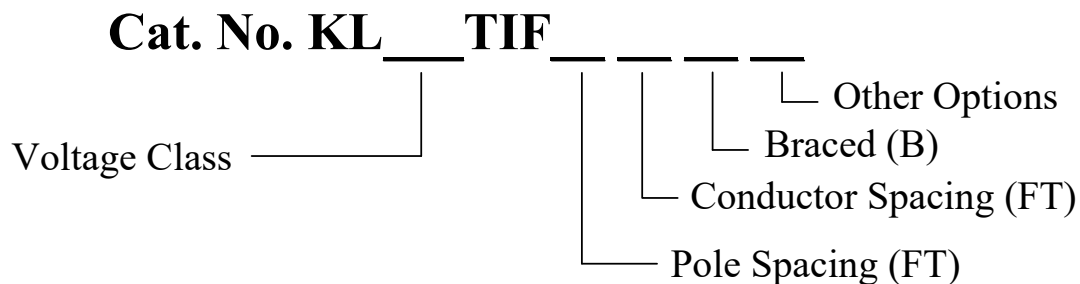

## Summary of TIF™ Silicone InsulArm Features/Advantages/Benefits:

(Patent No.: US 9,685,772)

- Attachment of Conductors direct to TIF™ Silicone InsulArm eliminates the need for Suspension Insulators on Transmission H-Frame type Tangent Structures
- Vertical Clearance increases up to 1 meter for 115 kV and 2 meters for 230 kV applications facilitate the use of shorter structures on new lines
- For Line “Uprating” projects, increased Vertical Clearances permit higher line operating currents and the resultant increase in Conductor Sags (refer to Figure 1)
- TIF™ reduces ROW width requirements. Conductors are mounted directly to TIF™ eliminating Suspension Insulator contribution to Conductor Swing (refer to Figure 2). Sample calculations give a reduction of almost one meter for 115 kV and approximately 1.5 meters for 230 kV applications
- Non-conductive TIF™ Silicone InsulArm improves safety of the application when working in Energized Line environments
- TIF™ eliminates Crossarm life limitations due to wood rot, hidden corrosion and deterioration of composite materials
- Modular Design of TIF™ simplifies transportation into difficult access areas in small, lightweight sections for assembly and installation in place without heavy transport or material handling equipment
- TIF™ Silicone InsulArm are Engineered and customized to fit existing H-Frame Pole Spacings
- Standard pole attachment hardware allows for TIF™ to simply bolt to Pole using existing holes on uprating/ Crossarm replacement projects
- TIF™ deters vandalism normally associated with glass and porcelain insulators in remote locations
- Silicone InsulArm protects wildlife by reducing possibilities of Phase-to-Ground Contacts from energized lines to conductive Crossarms. Irregular surfaces of alternating Insulator “Sheds” of Silicone InsulArms discourage bird roosting and nesting
- TIF™ enhances Transmission System Reliability and offers significant cost savings for line construction and maintenance
- TIF™ is ideal for Emergency Restoration or Emergency Bypass Construction

Figure 1

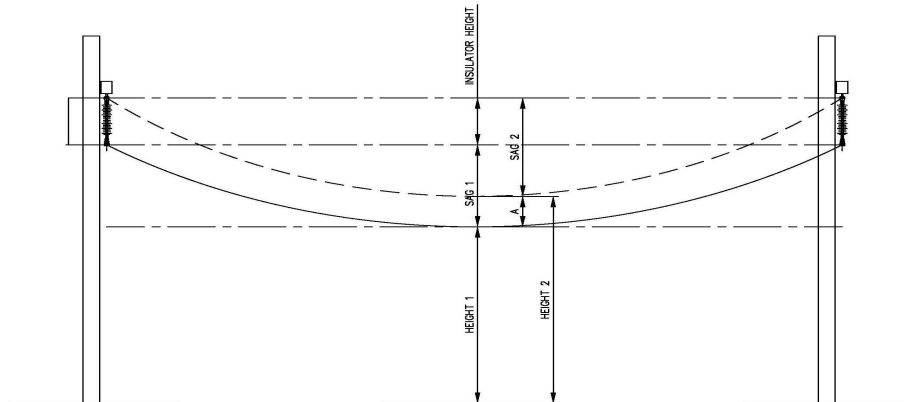
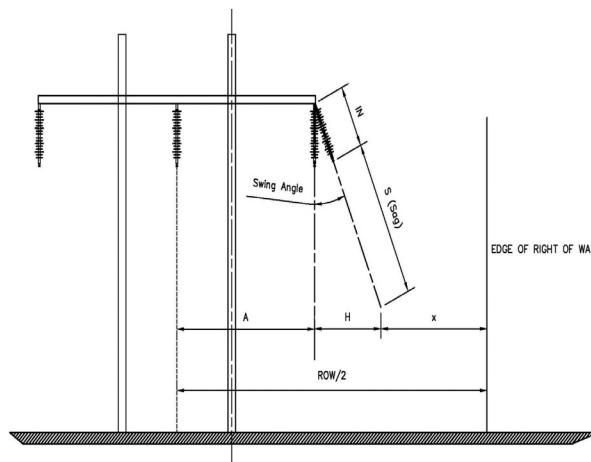

Figure 2



### **K-LINE INSULATORS LIMITED**

50 Passmore Avenue, Toronto, Ontario, Canada M1V 4T1

• Tel.: (416) 292-2008 • E-Mail: [insulators@k-line.net](mailto:insulators@k-line.net) • Web Page: [www.k-line.net](http://www.k-line.net)



**K-LINE INSULATORS LIMITED**  
TORONTO, ONTARIO, CANADA

# Catalogue D-RW

## **DISTRIBUTION SILICONE INSULATORS**

### *Railway*

### *15 kV to 69 kV*



ISO9001  
SAI GLOBAL  
FILE No. 000117

# Distribution Silicone Insulators Railway

Railway insulators perform an important role in maintaining railway system reliability. KLI insulators perform well in railway environments where rail dust, carbon particles, rust, and dirt can be present and combine with moisture. KLI insulators use a proprietary rubber formula which helps to give KLI insulators both hydrophobic and self-cleaning properties. The hydrophobic properties help water to form into droplets on insulator housing surfaces rather than forming a continuous film. These water droplets help to avoid losses from leakage currents and to mitigate system outages from power arc flashovers. Rainwater can help with natural self-cleaning when it washes away surface contaminants which often mitigates the need for insulator washing and helps to save on maintenance costs.

**K-LINE INSULATORS LIMITED** silicone rubber Railway Insulators are manufactured and tested in accordance with industry wide standards, CSA and ANSI.

**K-LINE INSULATORS LIMITED** is registered to ISO 9001 Quality Systems.

## PERFORMANCE BENEFITS

The performance benefits of **KLI** Distribution Railway Insulators are listed below.

- Improves Reliability (by mitigating interruptions and outages due to vandalism and flashovers in all types of environments)
- Eliminates or Reduces Maintenance (such as washing and trouble calls) and are compatible with existing installation
- Improves Power Quality (less RI and TVI)
- Energy Efficiency (lower losses due to lower leakage currents)
- Service Life (consistent performance over its service life)
- Life Cycle Cost (savings over ceramic insulators)

## APPLICATION

Distribution railway insulators are used on railway infrastructure operating between 15 kV to 69 kV. These insulators directly support the overhead catenary lines from the support structures in electrified systems. They prevent short circuiting and stray currents, ensuring mechanical stability by holding components in place.

## CORE ROD

The core rod of the insulator is made of a high-quality epoxy resin ECR rod that has been specially formulated for electrical and mechanical applications. Each and every rod is subjected to electrical testing to ensure the integrity of the core rods used in the production of all insulators. KLI's rod have a higher torsion strength rating than standard requirements to ensure safer installation and line operation.

## HOUSING

The housing (includes sheath and sheds) of the insulator is one piece, high temperature vulcanized, injection molded silicone rubber that is chemically bonded to the core rod. This ensures that the interface between the rubber and rod is impenetrable against moisture ingress. **KLI** uses its own proprietary silicone rubber formula in the manufacture of its insulators. The formulation has silicone rubber as the base polymer material with additives to enhance its performance in wet and contaminated environments.

# END FITTINGS

KLI offers different railway end fittings as illustrated below. The end fittings are manufactured from high strength steel or iron and are hot dipped galvanized to resist corrosion. The end fittings are crimped onto the insulator housing and core rod to provide excellent mechanical strength and reliable load-bearing performance. KLI designs use a robust, time-proven sealing design to help prevent moisture ingress which safeguards insulator integrity and helps to provide long-term durability and electrical and mechanical strength.

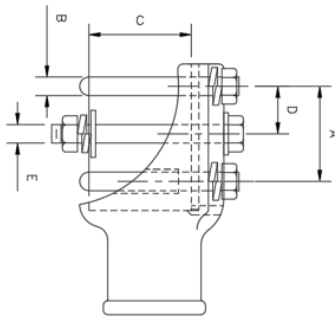

PIPE ADAPTER  
WITH CENTRE BOLT

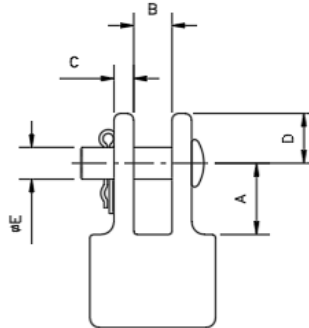

CLEVIS

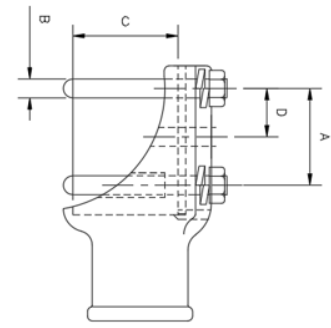

PIPE ADAPTER  
WITHOUT CENTRE BOLT

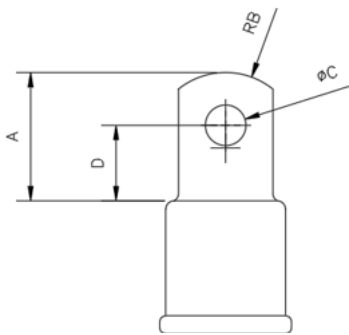

SHORT TONGUE

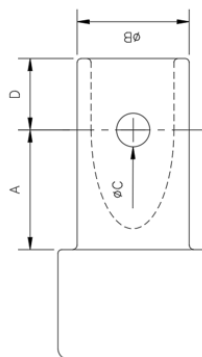

TUBE

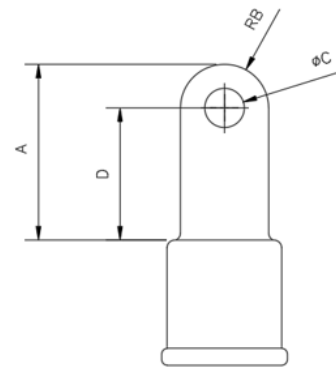

LONG TONGUE

## END FITTING DIMENSIONS

End Fitting	End Fitting Designation	Material	Dimensions (in.)				
			A	B	C	D	E
Clevis	C	Galv. Iron	1.395	0.765	0.39	0.975	0.625
Pipe Adapter (Without Center Bolt)	P	Galv. Iron	2.56	0.5	2.76	-	-
Pipe Adapter (With Center Bolt)		Galv. Iron	2.56	0.5	2.76	1.28	0.5
Short Tongue	T	Galv. Iron	2.676	1.575	0.847	1.57	-
Long Tongue	T	Galv. Iron	3.89	0.97	0.866	2.92	-
Tube	TU	Galv. Iron	1.975	1.86	0.555	1.18	-



### K-LINE INSULATORS LIMITED

50 Passmore Avenue, Toronto, Ontario, Canada M1V 4T1

• Tel.: (416) 292-2008 • E-Mail: [insulators@k-line.net](mailto:insulators@k-line.net) • Web Page: [www.k-line.net](http://www.k-line.net)

# DISTRIBUTION RAILWAY INSULATORS - 15 kV - 69 kV

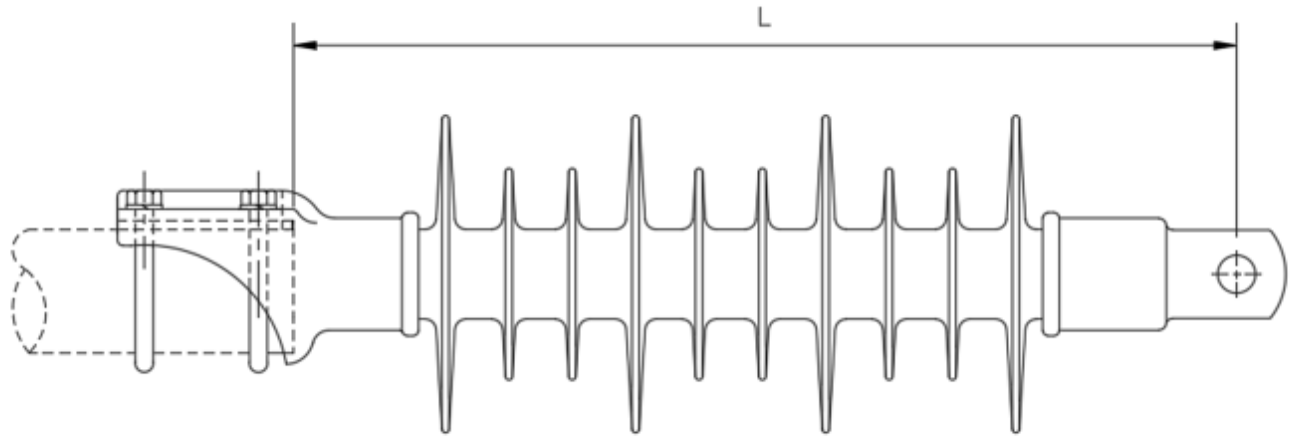

## TECHNICAL DATA

SPECIFICATIONS	UNIT	CATALOGUE NUMBER					
		KL15RWPT01	KL28RWCT1	KL35RWPT01	KL46RWPT01	KL69RWPT01	
Voltage Class	kV	15	28	35	46	69	
Nominal Voltage Rating	kV	11	20	25	38	69	
Section Length "L"	mm (in)	246 (9.8)	310 (12.2)	424 (16.7)	500 (19.7)	537 (21.1)	
Dry Arcing Distance	mm (in)	130 (5.1)	190 (7.5)	264 (10.4)	339 (13.3)	445 (17.5)	
Leakage Distance	mm (in)	259 (10.2)	420 (16.5)	657 (25.9)	860 (33.9)	1171 (46.1)	
Positive Critical Impulse Flashover	kV	125	160	195	240	300	
Low Frequency Flashover	Dry	kV	70	95	120	145	190
	Wet	kV	40	65	85	115	150
Approx. Weight	kg (lbs.)	5.9 (13.1)	3.3 (7.4)	7.3 (16.2)	7.7 (17.0)	8.4 (18.5)	
Standard Packaging	-	2	3	2	2	2	

## ORDERING INFORMATION

For ordering, the catalog number of the specific insulator is formulated as shown below:

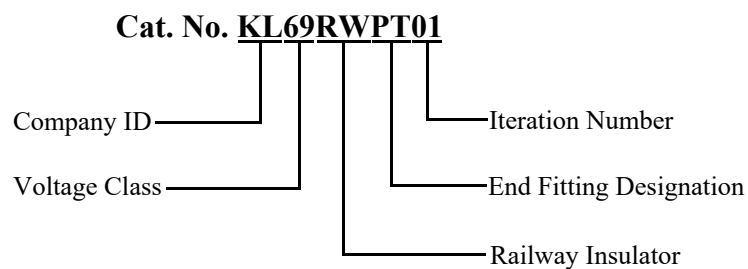



**K-LINE INSULATORS LIMITED**  
TORONTO, ONTARIO, CANADA

# Catalogue T-BP

## **TRANSMISSION SILICONE INSULATORS** *Braced Post* *69 kV to 230 kV*



**ISO9001**  
**SAI GLOBAL**  
**FILE No. 000117**

# Transmission Silicone Braced Post

Braced Post Insulators offer a high performance solution for modern high-voltage transmission systems. Operating between 69 kV and 230 kV, they have been designed to optimize both line compaction and mechanical strength. This is achieved through the combination of a horizontal line post with the tensile strength of a suspension brace insulator to deliver an assembly with high-strength tolerance. These assemblies provide the mechanical strength to withstand high wind and ice loading conditions, while also mitigating the conductor swing associated with traditional suspension assemblies.

**K-LINE INSULATORS LIMITED** silicone rubber Braced Post Insulators are manufactured and tested in accordance with industry-wide standards, CSA and ANSI.

**K-LINE INSULATORS LIMITED** is registered to ISO 9001 Quality Systems.

## PERFORMANCE BENEFITS

The performance benefits of **KLI** Braced Post Insulators are listed below.

- Improves Reliability (interruptions and outages due to vandalism, pole fires, and flashovers in all types of environments)
- Eliminates or Reduces Maintenance (such as washing and fewer trouble calls) and are compatible with existing installation
- Improves Power Quality (lower RI and TVI)
- Energy Efficiency (reduced losses due to lower leakage currents)
- Safety (light weight for handling and installation)
- Service Life (consistent performance over its service life)
- Life Cycle Cost (savings over ceramic insulators)
- High Strength Tolerance (mitigates conductor swing under wind & ice loading)

## APPLICATION

Braced Post insulators are used on overhead transmission lines operating between 69 kV and 230 kV. These insulators are installed horizontally on metal or wooden structures. A suspension insulator connects to the line-end of the post and attaches to the pole at a higher point forming a triangular brace for the transmission lines.

## CORE ROD

The core rod of the insulator is made of a high quality, epoxy resin, ECR rod that has been specially formulated for electrical and mechanical applications. Each and every rod is subjected to electrical testing to ensure the integrity of the core rods used in production of all insulators. KLI's rod have a higher torsion strength rating than standard requirements to support safer installation and line operation.

## HOUSING AND SHEDS

The housing (includes sheath and sheds) of the insulator is one piece, high temperature vulcanized, injection molded silicone rubber that is chemically bonded to the core rod. This ensures that the interface between the rubber and rod is impenetrable against moisture ingress. KLI uses its own proprietary silicone rubber formula in the manufacture of its insulators. The formulation has silicone rubber as the base polymer material with additives to enhance its performance in wet and contaminated environments.

# TRANSMISSION BRACED POST FIXED BASE AND FLAT BRACKET 69 kV to 230 kV

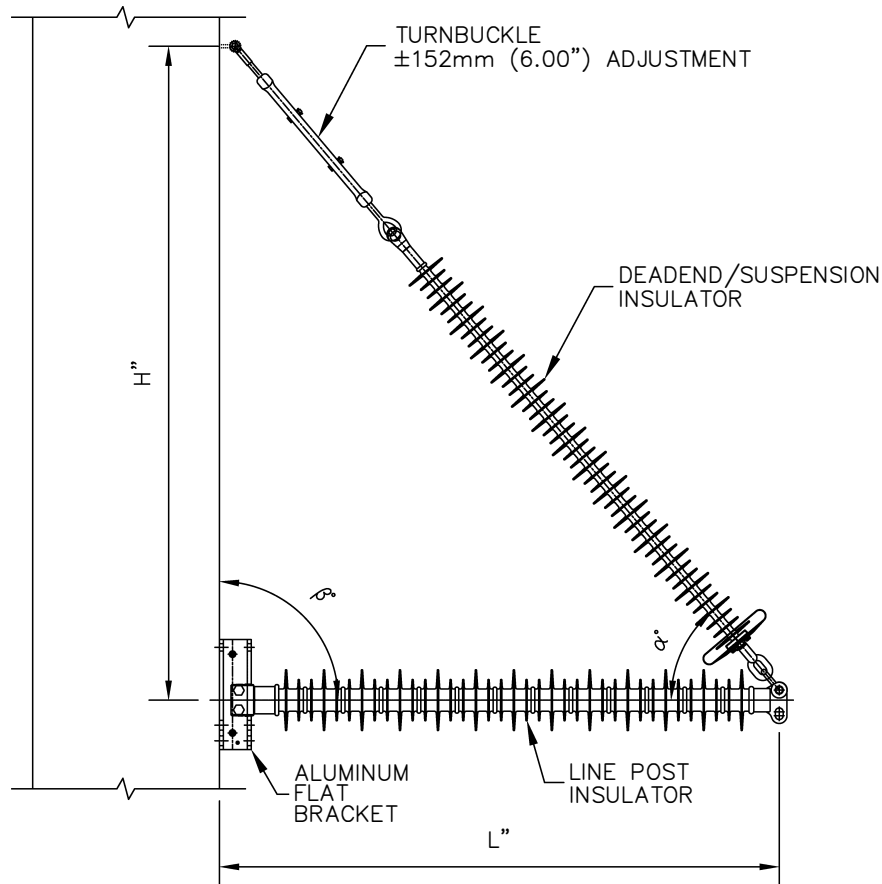

ITEM	SPECIFICATION	DATA
1	Operating Voltage (Phase to Phase)	kV
2	Mounting Arrangement Code (Refer to Table on Page x)	
3	Length "L"	in
4	Height "H"	in
5	Minimum Dry Arc Distance	in
6	Minimum Leakage Distance	in
7	Minimum Loading Capabilities - Vertical, Transverse, Longitudinal	lbs., lbs., lbs.
8	Alpha Angle ( $\alpha$ )	°
9	Beta Angle ( $\beta$ )	°
10	Minimum Hinge Angle For Pivot Base (X) - Must Be Included In	°
11	Design Preference For Turnbuckle or Guy Strain	

**NOTE:**

1. IF ORDER SPECIFICATIONS ARE NOT AVAILABLE, PLEASE CONTACT KLI FOR DETAILS

# TRANSMISSION BRACED POST FIXED BASE AND CURVED BRACKET 69 kV to 230 kV

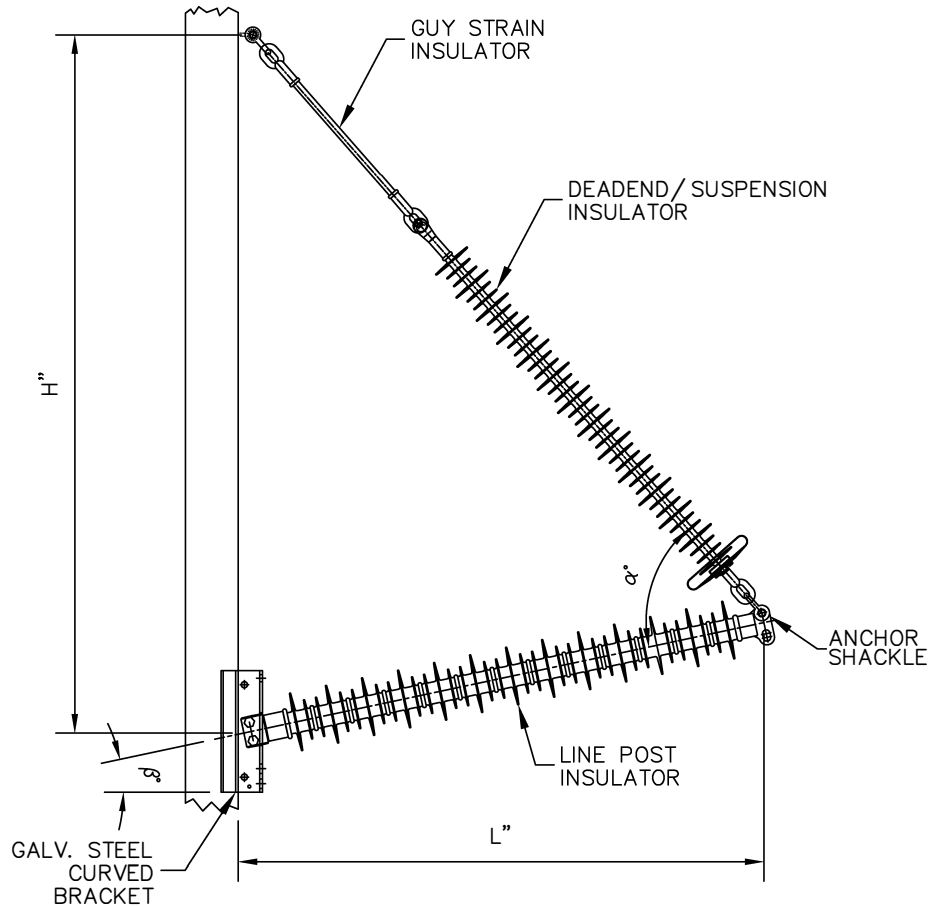

ITEM	SPECIFICATION	DATA
1	Operating Voltage (Phase to Phase)	kV
2	Mounting Arrangement Code (Refer to Table on Page x)	
3	Length "L"	in
4	Height "H"	in
5	Minimum Dry Arc Distance	in
6	Minimum Leakage Distance	in
7	Minimum Loading Capabilities - Vertical, Transverse, Longitudinal	lbs., lbs., lbs.
8	Alpha Angle ( $\alpha$ )	°
9	Beta Angle ( $\beta$ )	°
10	Minimum Hinge Angle For Pivot Base (X) - Must Be Included In	°
11	Design Preference For Turnbuckle or Guy Strain	

**NOTE:**

1. IF ORDER SPECIFICATIONS ARE NOT AVAILABLE, PLEASE CONTACT KLI FOR DETAILS

# TRANSMISSION BRACED POST PIVOTING BASE 69 kV to 230 kV

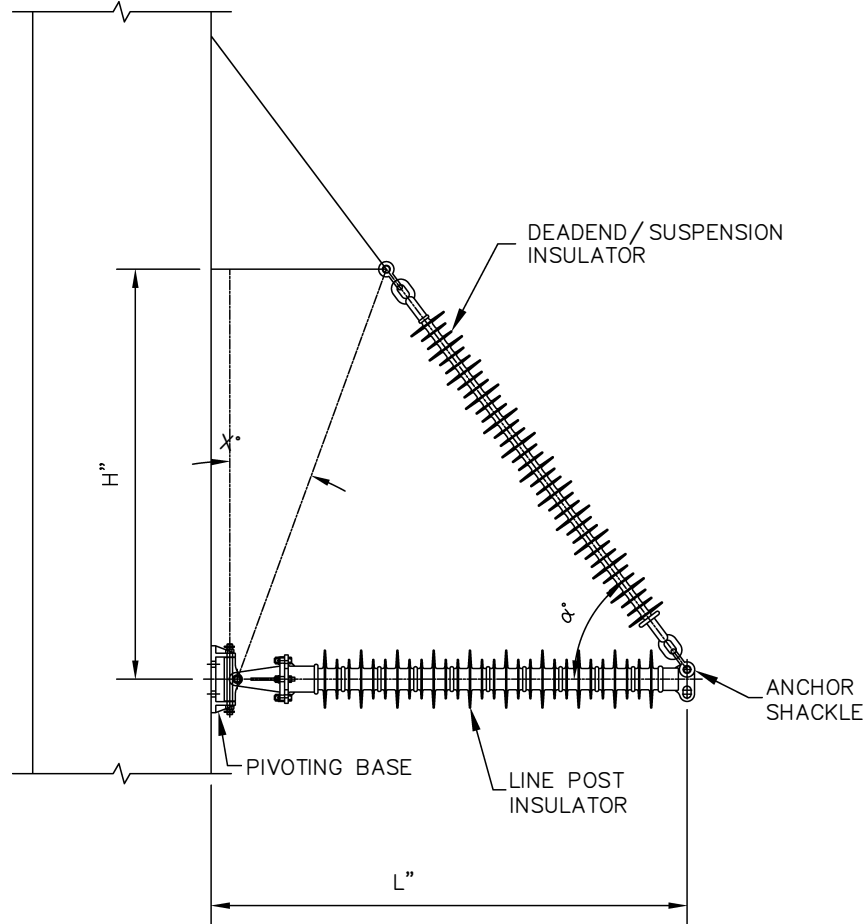

ITEM	SPECIFICATION	DATA
1	Operating Voltage (Phase to Phase)	kV
2	Mounting Arrangement Code (Refer to Table on Page x)	
3	Length "L"	in
4	Height "H"	in
5	Minimum Dry Arc Distance	in
6	Minimum Leakage Distance	in
7	Minimum Loading Capabilities - Vertical, Transverse, Longitudinal	lbs., lbs., lbs.
8	Alpha Angle ( $\alpha$ )	°
9	Beta Angle ( $\beta$ )	°
10	Minimum Hinge Angle For Pivot Base (X) - Must Be Included In	°
11	Design Preference For Turnbuckle or Guy Strain	

**NOTE:**

- IF ORDER SPECIFICATIONS ARE NOT AVAILABLE, PLEASE CONTACT KLI FOR DETAILS

# BASE BRACKETS

**K-LINE** Braced Post Insulators are available in several different base brackets as illustrated below. These brackets are manufactured from high strength steel or aluminum and are hot dipped galvanized to resist corrosion. The brackets are available in either a 12° or 90° orientations.

For other specialty brackets & configurations please contact **KLI**.

**B19/B8**

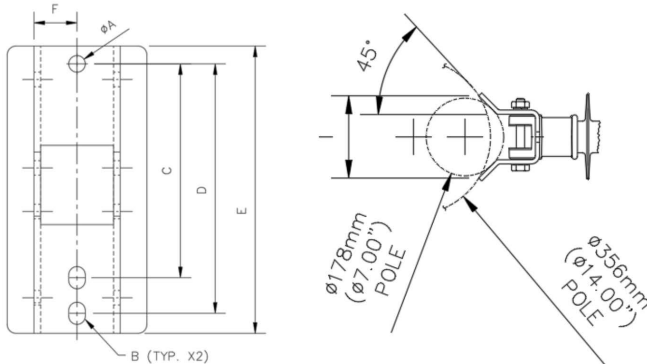

**B19F08/B5F08**

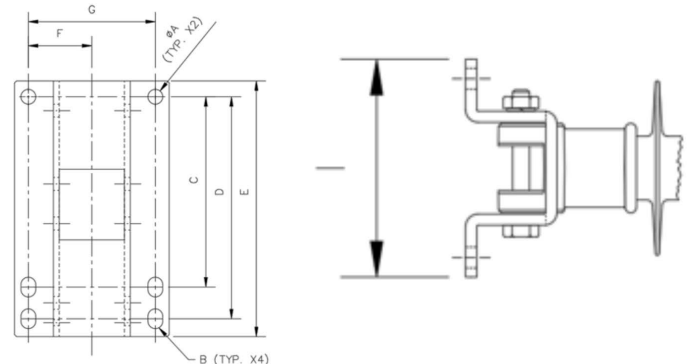

**B19/F8**

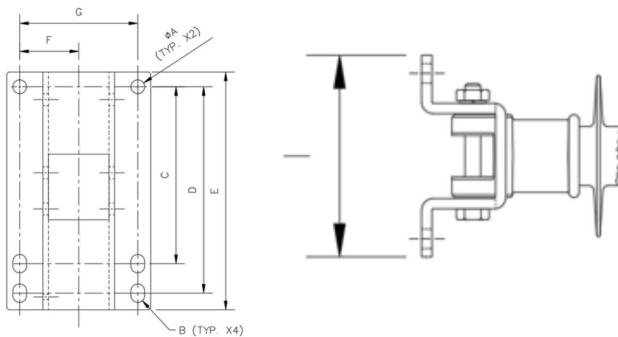

**B/B3**

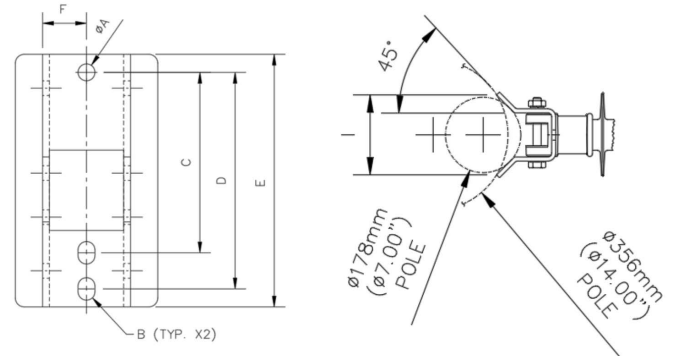

**NOTE:**

1. BRACKETS AVAILABLE IN GALVANIZED STEEL AND ALUMINUM OPTIONS
2. ALTERNATIVE DESIGNS AND BOLT PATTERNS ARE AVAILABLE UPON REQUEST. PLEASE CONTACT KLI



**K-LINE INSULATORS LIMITED**

50 Passmore Avenue, Toronto, Ontario, Canada M1V 4T1

• Tel.: (416) 292-2008 • E-Mail: [insulators@k-line.net](mailto:insulators@k-line.net) • Web Page: [www.k-line.net](http://www.k-line.net)

# BASE BRACKETS

BF08/B3F08

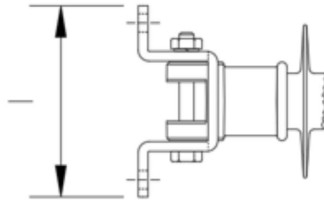
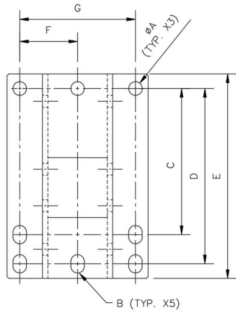

BF8/B3F8

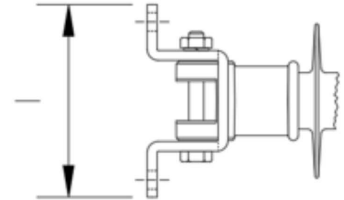
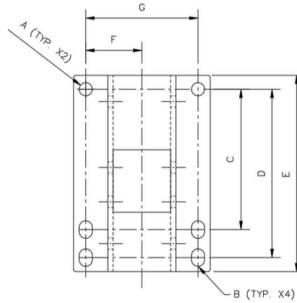

**NOTE:**

1. BRACKETS AVAILABLE IN GALVANIZED STEEL AND ALUMINUM OPTIONS
2. ALTERNATIVE DESIGNS AND BOLT PATTERNS ARE AVAILABLE UPON REQUEST. PLEASE CONTACT KLI

## AVAILABLE ORIENTATIONS

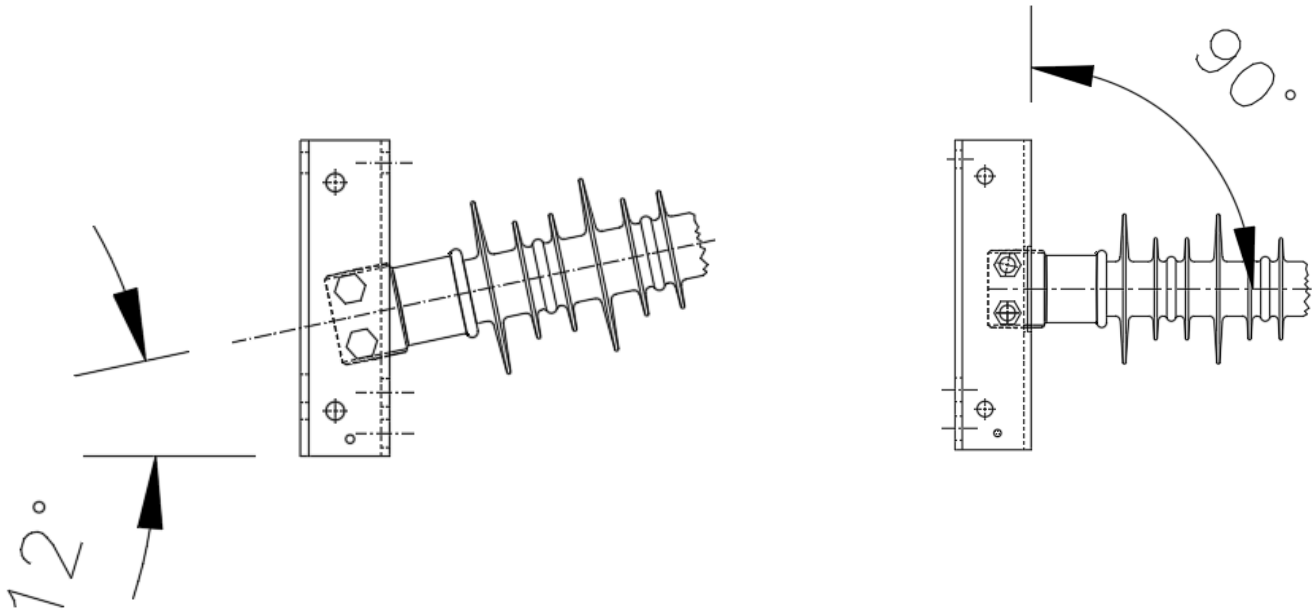

## BASE END FITTING DIMENSIONS

Mounting Bracket Code	Flat/Curved/Pivot	Post Angle	Material	Dimensions (in.)								
				A	B	C	D	E	F	G	I	
B/B3	Curved	12	Galv. Steel/Aluminum	0.938	0.938X1.250	10.000	12.000	14.000	2.425	-	7.405	
BF8/B3F8	Flat	12	Galv. Steel/Aluminum	0.938	0.938X1.250	10.000	12.000	14.000	4.000	8.000	9.750	
BF08	Flat	0	Galv. Steel	0.938	0.938X1.250	10.000	12.000	14.000	4.000	8.000	9.750	
B19/B8	Curved	12	Galv. Steel/Aluminum	0.938	0.938X1.250	12.000	14.000	16.125	2.425	-	7.405	
B19F8	Flat	12	Galv. Steel	0.938	0.938X1.250	12.000	14.000	16.125	4.000	8.000	9.750	
B19F08/B5F08	Flat	0	Galv. Steel	0.938	0.938X1.250	12.000	14.000	16.125	4.000	8.000	9.750	