

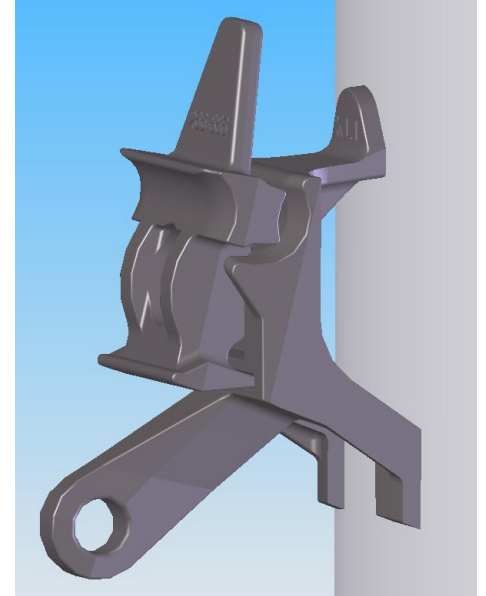

K-LINE INSULATORS LIMITED  
TORONTO, ONTARIO, CANADA

# Catalogue: Hardware

## "SCORPION" Neutral Conductor Clamp

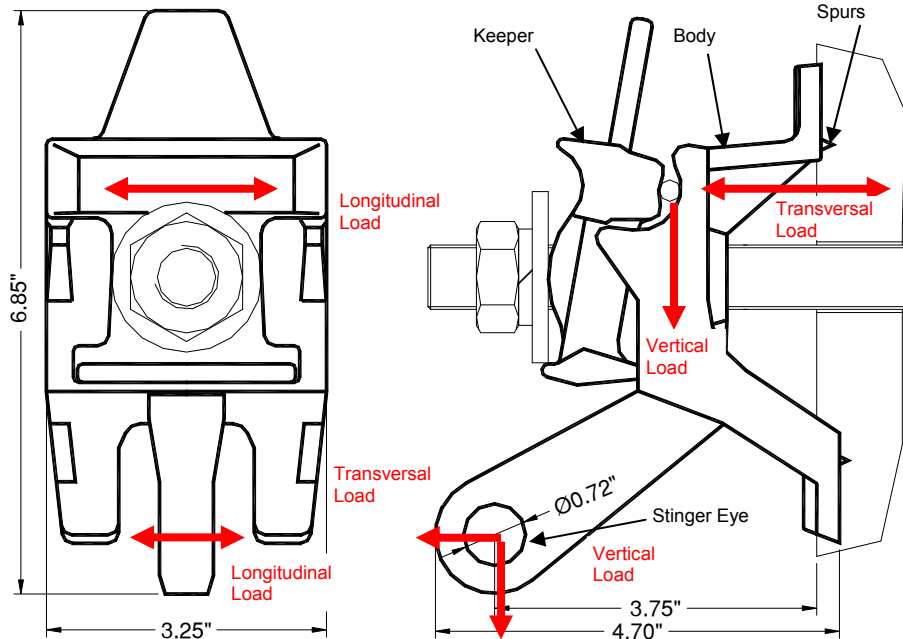

The "SCORPION" Neutral Conductor Clamp was developed specifically to address the expressed needs of Customers using a wide range of Neutral Conductor sizes, including large diameter conductors. The Galvanized Iron "SCORPION" was designed to accommodate Conductor sizes from #4 AWG to 715 kcmil. The Stinger Eye has a 0.72" diameter hole for temporary support of Conductor Stringing Rollers during line construction. The Stinger Eye also serves as a permanent attachment point for an Overhead Secondary Service Tap. The "SCORPION" is supplied with a Round Washer and Lock Washer, Spurs or no Spurs and installed with Customer supplied 3/4" Bolt Hardware.

### FEATURES:

**Material:** Ductile Iron, Hot Dip Galvanized.

**Mounting Spurs** for Wood Pole. **No Spurs** for Steel, Concrete, and Composite Poles.

**Conductor Range:** 0.20" (#4 AWG) to 0.98" (715 kcmil AAC)

**Maximum Line Angle:** 15°

**Stinger Eye:** For the attachment of a Stringing Roller during conductor installation or Secondary Service Tap.

**Pole Mounting:** The SCORPION is shipped with one 3/4" flat round washer (max. 2" OD and min. 0.14" thick) and one 3/4" lock washer. The bolt and nut are customer supplied at appropriate length. The installation torque for the 3/4"-10 UNC bolt and nut is 130 ft•lbs.



ISO9001  
SAI GLOBAL  
FILE No. 000117

## CLAMPS

Catalogue Number	Mounting Spurs	Body Tapped	Weight per Unit	Standard Packaging
KLOP-HWCP08-A	Yes	3/4"-10 UNC Bolt	4.5 lbs.	12 Units per box
KLOP-HWCP08-B	No			

## MAXIMUM DESIGN LOADS

	Maximum Design Loads	kN (lbs)
Loads supported by <b>Neutral Clamp (Body and Keeper)</b>	Maximum Design Slip Load (MDSL) for a 0.850" dia. conductor	5.5 (1,250)
	Maximum Design Transversal Load (MDTL) on Keeper	10.0 (2,250)
	Maximum Design Transversal Load (MDTL) on Body	13.0 (2,900)
	Maximum Design Vertical Load (MDVL)	13.0 (2,900)
Loads supported by <b>Neutral Clamp Stinger Eye</b>	Maximum Design Transversal Load (MDTL)	11.0 (2,500)
	Maximum Design Vertical Load (MDVL)	12.5 (2,800)

### NOTES:

The MAXIMUM DESIGN LOADS are allowable loads

The Loads are independent



### **K-LINE INSULATORS LIMITED**

50 Passmore Avenue, Toronto, Ontario, Canada M1V 4T1

• Tel.: (416) 292-2008 • E-Mail: [insulators@k-line.net](mailto:insulators@k-line.net) • Web Page: [www.k-line.net](http://www.k-line.net)