



**K-LINE INSULATORS LIMITED**  
TORONTO, ONTARIO, CANADA

# Catalogue D-RS

## DISTRIBUTION SILICONE INSULATORS

### *Riser Support* *15 kV to 69 kV*

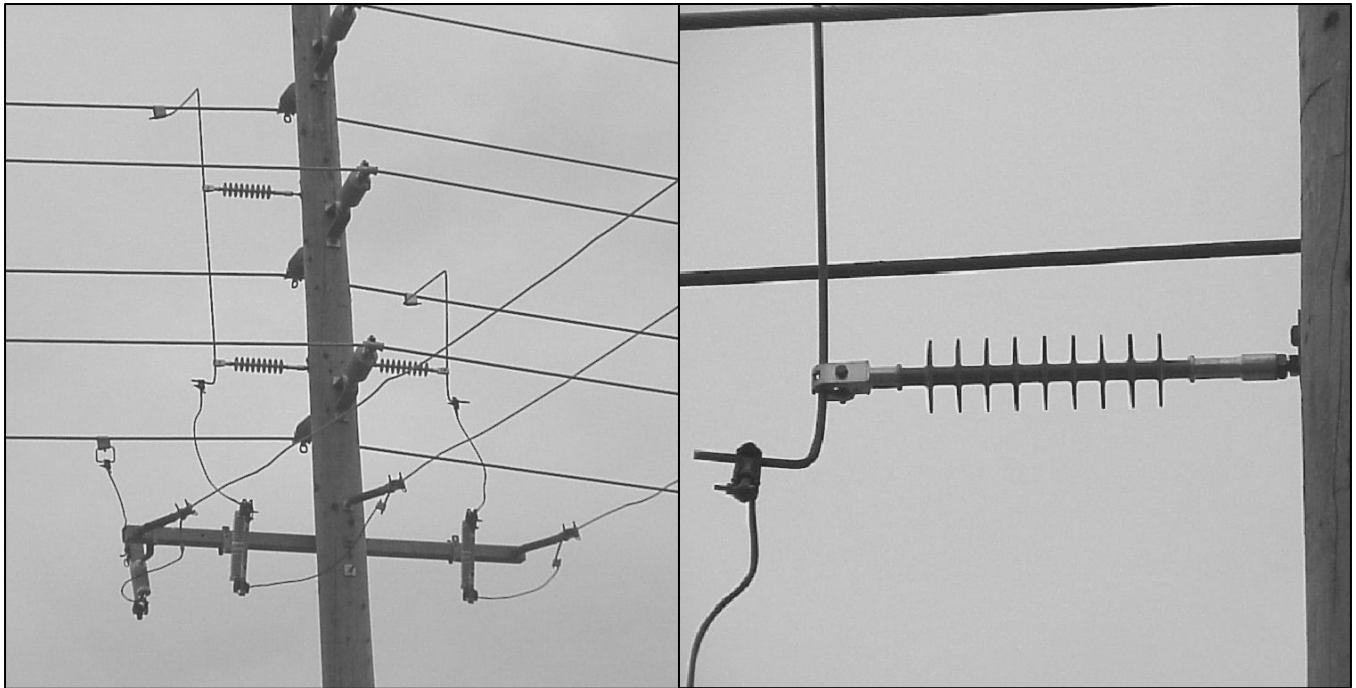

ISO9001  
SAI GLOBAL  
FILE No. 000117

# Distribution Silicone Insulators

## Riser Support

On distribution overhead lines there are numerous tap-offs from the main line to provide connections to equipment (e.g., transformers, switches, fuses, underground cables, etc.) or lines (e.g., services, junctions, etc.). Normally leads are used to connect the equipment or line to the main line. These leads can be long and difficult or hazardous to operate. The use of riser support insulators can provide a safe and economical support for these leads.

**K-LINE INSULATORS LIMITED (KLI)** silicone riser support insulators are manufactured and tested in accordance with industry wide standards, CSA, ANSI and IEC.

**K-LINE INSULATORS LIMITED** is registered to ISO 9001 Quality Systems.

### APPLICATION

Distribution riser support insulators are used on distribution lines operating at or below 69 kV. These insulators are installed on metal, concrete or wooden structures, standoff brackets and cross arms to hold and insulate conductor leads.

### CORE ROD

The core rod of the insulator is made of a high quality, epoxy resin, E-Glass fiberglass rod that has been specially formulated for electrical and mechanical applications.

### HOUSING

The housing (includes sheath and sheds) of the insulator is one piece, high temperature vulcanized, injection molded silicone rubber that is chemically bonded to the core rod. This ensures that the interface between the rubber and rod is impenetrable against moisture ingress. **KLI** uses its own proprietary silicone rubber formula in the manufacture of its insulators. The formulation has silicone rubber as the base polymer material with additives to enhance its performance in wet and contaminated environments.

### FITTINGS

The riser insulator comes standard with a clamp to hold the conductor and a threaded base for mounting to apparatus.

#### **Conductor Clamp**

The clamp is an aluminum clamp that can accommodate copper or aluminum conductors 5.0mm to 23.5mm (0.20" to 0.95").

#### **Threaded Base**

The base is typically threaded for 5/8"-11, 3/4"-10, M16x2, or M20x2.5 galvanized bolt.

For other special clamp features or base threads please contact **KLI**.

# DISTRIBUTION RISER SUPPORT INSULATORS

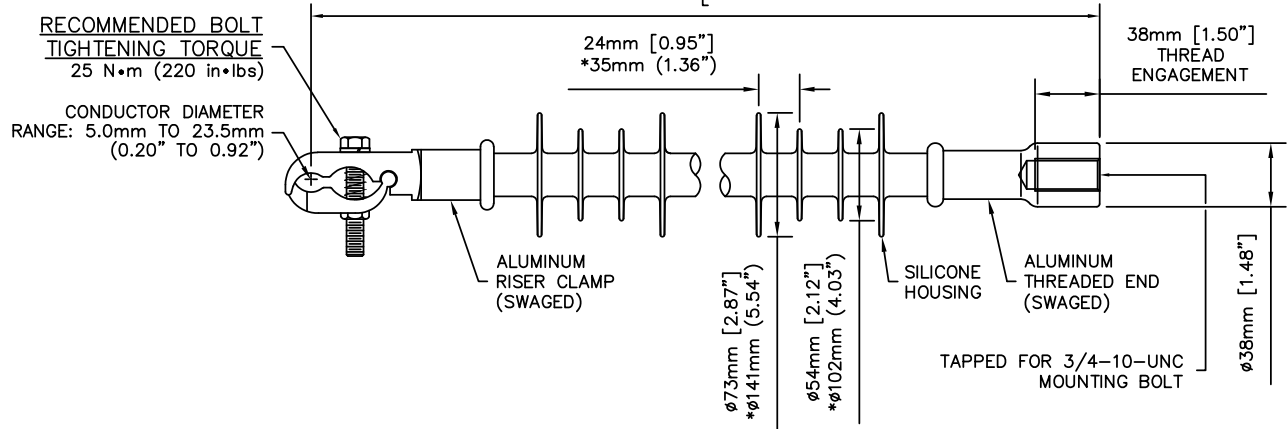

KL15ARSIU, KL28ARSIU & \*KL69HRSIU16

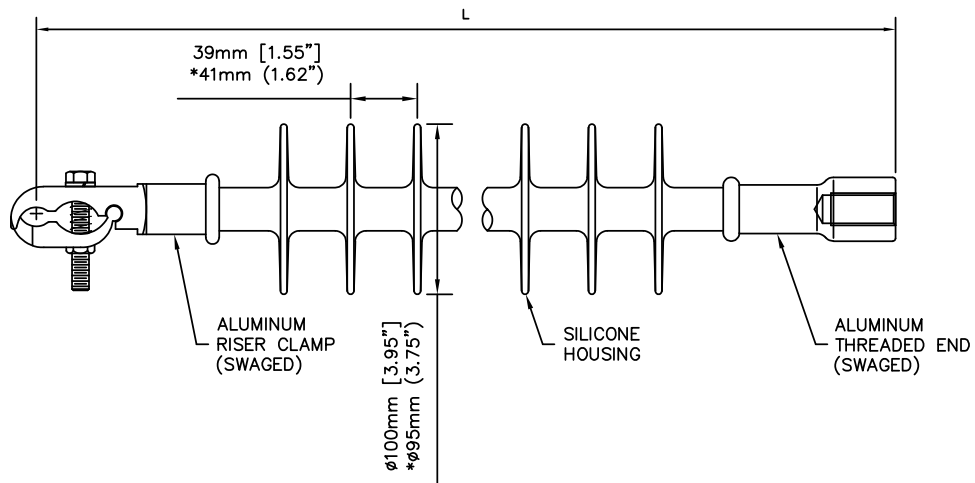

\*KL35SRSIU & KL46SRSIU

## TECHNICAL DATA

SPECIFICATIONS	UNIT	CATALOGUE NUMBER**					
		KL15ARSIU	KL28ARSIU	KL35SRSIU	KL46SRSIU	KL69HRSIU16	
Voltage Class	kV	15	28	35	46	69	
Section Length "L"	mm (in)	370 (14.6)	480 (18.9)	534 (21.0)	600 (23.6)	766 (30.2)	
Dry Arcing Distance	mm (in)	193 (7.6)	290 (11.4)	348 (13.7)	419 (16.5)	627 (24.7)	
Leakage Distance	mm (in)	384 (15.1)	590 (23.2)	750 (29.5)	988 (38.9)	1798 (70.8)	
Low-Frequency Flashover	Dry	kV	100	135	155	180	260
	Wet	kV	75	100	145	150	245
Critical Impulse Flashover (Pos.)	kV	150	225	265	300	425	
Specified Cantilever Load (SCL)	kN (lb)	1.7 (381)	1.2 (270)	1.1 (237)	0.9 (205)	0.7 (155)	
Max. Design Cantilever Load (MDCL)	kN (lb)	0.42 (95)	0.27 (60)	0.20 (45)	0.15 (35)	0.09 (20)	
Approx. Weight	kg (lb)	0.7 (1.5)	0.9 (1.9)	2.1 (4.7)	2.2 (4.8)	2.3 (5.1)	
Standard Packaging	-	18	18	12	12	6	

\*\* Options: For 5/8" tapped hole add 'X', for M16 add 'M16', or for M20 add 'M20' and for tin-plated clamp add 'D' to the catalogue number.



### K-LINE INSULATORS LIMITED

50 Passmore Avenue, Toronto, Ontario, Canada M1V 4T1

• Tel.: (416) 292-2008 • E-Mail: [insulators@k-line.net](mailto:insulators@k-line.net) • Web Page: [www.k-line.net](http://www.k-line.net)