

Standoff Brackets for Line Post Insulators

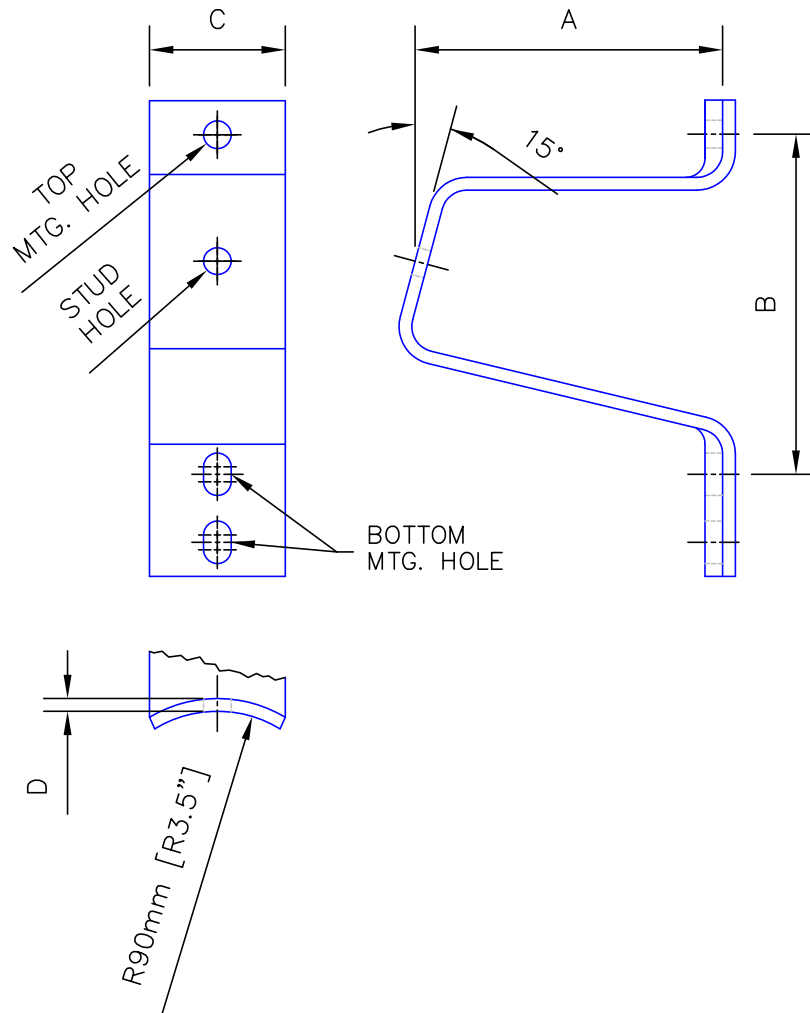

Material: Galvanized Steel

KLI PART No.	A mm (in)	B mm (in)	C mm (in)	D mm (in)	STUD HOLE in	TOP MTG. HOLE mm (in)	BOTTOM MTG. SLOT in	No. OF BOTTOM MTG. HOLE
KLOP149	76 (3)	255 (10)	102 (4)	10 (0.38)	13/16	21 (0.81)	0.81x1.25	1
KLOP-HWBK08	76 (3)	255/305 (10/12)	102 (4)	10 (0.38)	13/16	21 (0.81)	0.81x1.25	2
KLMP-BK03	76 (3)	255/305 (10/12)	127 (5)	13 (0.50)	15/16	21 (0.81)	0.81x3.25	2
KLOP056	230 (9)	255 (10)	102 (4)	10 (0.38)	13/16	21 (0.81)	0.81x1.25	1
KLOP056-1	230 (9)	255/305 (10/12)	102 (4)	10 (0.38)	13/16	21 (0.81)	0.81x1.25	2
KLMP-BK02	230 (9)	305 (12)	127 (5)	13 (0.50)	15/16	23 (0.90)	0.90x1.25	1
KLOP-GB10-18	457 (18)	255 (10)	102 (4)	10 (0.38)	13/16	21 (0.81)	0.81x1.25	1



K-LINE INSULATOR LIMITED

50 Passmore Avenue, Toronto, Ontario, Canada M1V 4T1

• Tel.: (416) 292-2008 • Fax: (416) 292-2094

• E-Mail: insulators@k-line.net • Web Page: www.k-line.net

Trunnion Clamp for Line Post Insulators

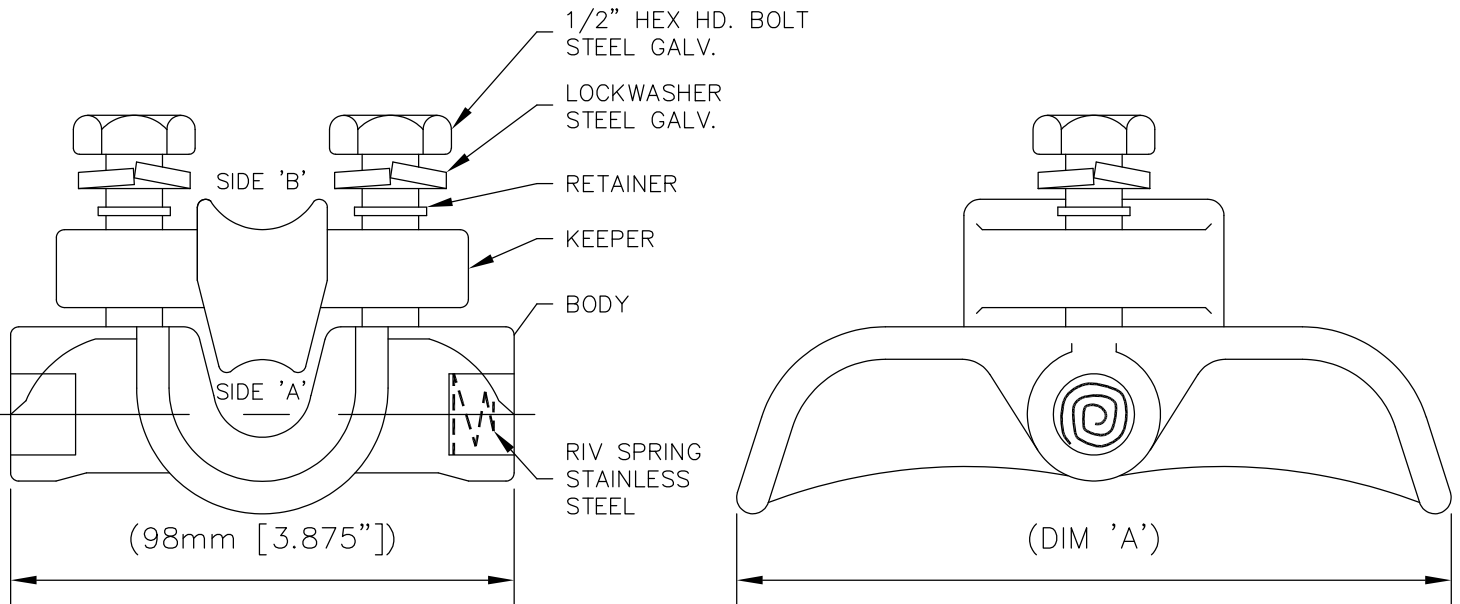

TABLE

PART No.	MATERIAL (BODY & KEEPER)	CONDUCTOR RANGE		DIM. A mm (in)
		SIDE 'A' mm (in)	SIDE 'B' mm (in)	
KLOP026	ALUMINUM	6.4–19.1 (0.25–0.75)	15.7–27.2 (0.62–1.07)	140 (5.50)
KLOP026I	MALLEABLE IRON GALVANIZED	6.4–19.1 (0.25–0.75)	15.7–27.2 (0.62–1.07)	140 (5.50)
KLOP173	ALUMINUM	25.4–31.8 (1.00–1.25)	32.0–38.1 (1.26–1.50)	133 (5.25)
KLOP059	ALUMINUM	38.1–44.5 (1.5–1.75)	44.7–50.8 (1.76–2.00)	133 (5.25)



K-LINE INSULATOR LIMITED

50 Passmore Avenue, Toronto, Ontario, Canada M1V 4T1

• Tel.: (416) 292-2008 • Fax: (416) 292-2094

• E-Mail: insulators@k-line.net • Web Page: www.k-line.net

Studs for Line Post Insulators

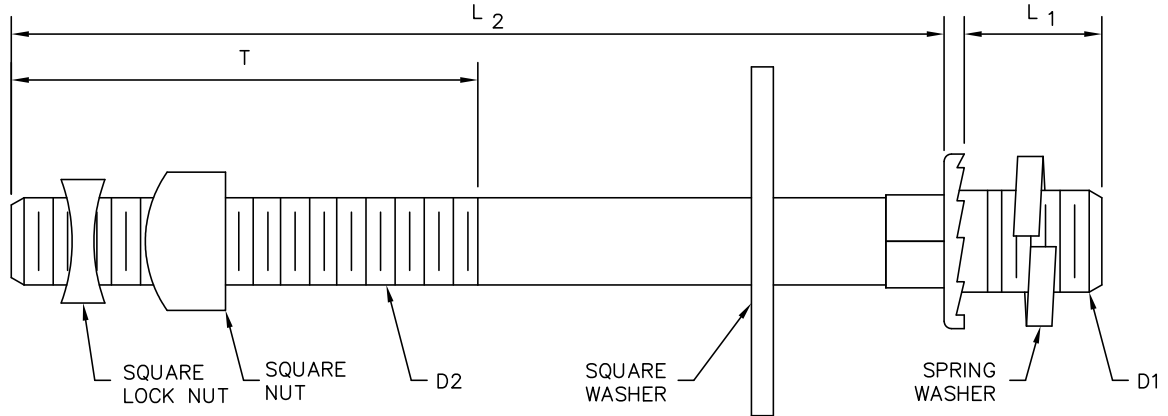

LONG STUD

TABLE 1

KLI Part No.	D1	D2	L ₁	L ₂	T	Washer Size
KLOP032B	3/4"-10UNC	5/8"-11 UNC	1"	6"	4"	2-1/4" x 2-1/4"
KLOP032	3/4"-10 UNC	5/8"-11 UNC	1"	6"	2-1/2"	2" x 2"
KLOP153	3/4"-10 UNC	3/4"-10 UNC	1"	7-1/2"	4"	2-1/4" x 2-1/4"
KLOP032E	3/4"-10 UNC	3/4"-10 UNC	1"	6"	5"	3" x 3"
KLOP032C	3/4"-10 UNC	3/4"-10 UNC	1"	7-1/2"	4"	3" x 3"
KLOP-HWBP03	7/8"-9 UNC	3/4"-10 UNC	1-1/4"	7-1/2"	4"	3" x 3"
KLOP032D	7/8"-9 UNC	7/8"-9 UNC	1-1/4"	8"	4"	3" x 3"

Note: Item KLOP032 has a hex nylock nut.

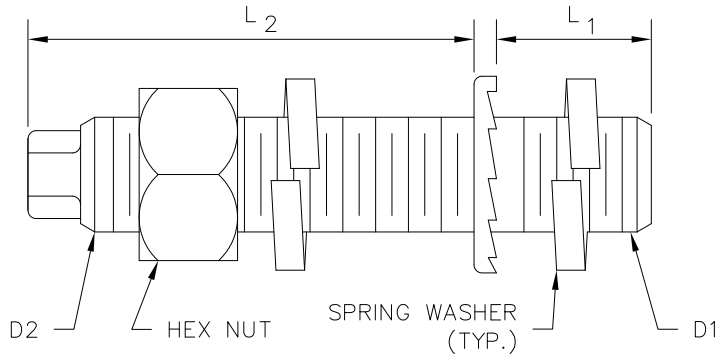

SHORT STUD

TABLE 2

KLI Part No.	D1	D2	L ₁	L ₂
KLOP027	3/4"-10 UNC	3/4"-10 UNC	1"	2-1/4"
KLOP027A	3/4"-10 UNC	3/4"-10 UNC	1"	2-1/2"
KLOP027B	7/8"-9 UNC	7/8"-9 UNC	1-1/4"	3-1/2"

Material: Steel, Hot Dipped Galvanized.

Dimension: L₁, L₂ & T are approximate.



K-LINE INSULATOR LIMITED

50 Passmore Avenue, Toronto, Ontario, Canada M1V 4T1

• Tel.: (416) 292-2008 • Fax: (416) 292-2094

• E-Mail: insulators@k-line.net • Web Page: www.k-line.net