



K-LINE INSULATORS LIMITED
TORONTO, ONTARIO, CANADA

Catalogue D-SP

DISTRIBUTION SILICONE INSULATORS

Station Post

15 kV to 46 kV



ISO9001
SAI GLOBAL
FILE No. 000117

Distribution Silicone Insulators Station Post

One of the most critical assets of an electrical Distribution System is the station. Not only is this asset the heart of the supply to large electrical loads but it also serves many customers from industrial to residential. Therefore, power outages or interruptions due to insulation failures are costly and impact negatively on customer service. With **K-LINE INSULATORS LIMITED (KLI)** silicone Station Post Insulators these are greatly minimized through improved performance to reliability and savings in the life cycle cost.

Silicone's hydrophobic property allows **KLI** Station Post Insulators to electrically outperform ceramic insulators. The lightweight feature of polymer insulators makes them easy to handle and install. The size and fittings of polymer Station Post Insulators ensure that they are compatible with existing Station Post hardware and arrangements. Experience with silicone polymer insulators has proven their superiority over ceramic insulators.

KLI silicone Distribution Station Post Insulators are manufactured and tested in accordance with industry wide standards, CSA and ANSI.

K-LINE INSULATORS LIMITED is registered to ISO 9001 Quality Systems.

PERFORMANCE BENEFITS

The performance benefits of **KLI** Distribution Station Post Insulators are listed below.

- Improves Reliability (by mitigating interruptions and outages due to vandalism, and flashovers in all types of environments)
- Eliminates or Reduces Maintenance (such as washing and trouble calls) and are compatible with existing installation
- Improves Power Quality (lower RI and TVI)
- Energy Efficiency (reduced losses due to lower leakage currents)
- Safety (light weight for handling and installation, eliminates catastrophic mechanical failures)
- Service Life (consistent performance over its service life)
- Life Cycle Cost (savings over ceramic insulators)

APPLICATION

Distribution Station Post Insulators are used in open-type stations operating at and below 46 kV. These insulators support the bus, leads, or other apparatus within the station.

CORE ROD

The core rod of the insulator is made of a high quality, epoxy resin, E-Glass fiberglass rod that has been specially formulated for electrical and mechanical applications.

HOUSING

The housing (includes sheath and sheds) of the insulator is one piece, high temperature vulcanized, injection molded silicone rubber that is chemically bonded to the core rod. This ensures that the interface between the rubber and rod is impenetrable against moisture ingress. **KLI** uses its own proprietary silicone rubber formula in the manufacture of its insulators. The formulation has silicone rubber as the base polymer material with additives to enhance its performance in wet and contaminated environments.

DISTRIBUTION STATION POST INSULATORS

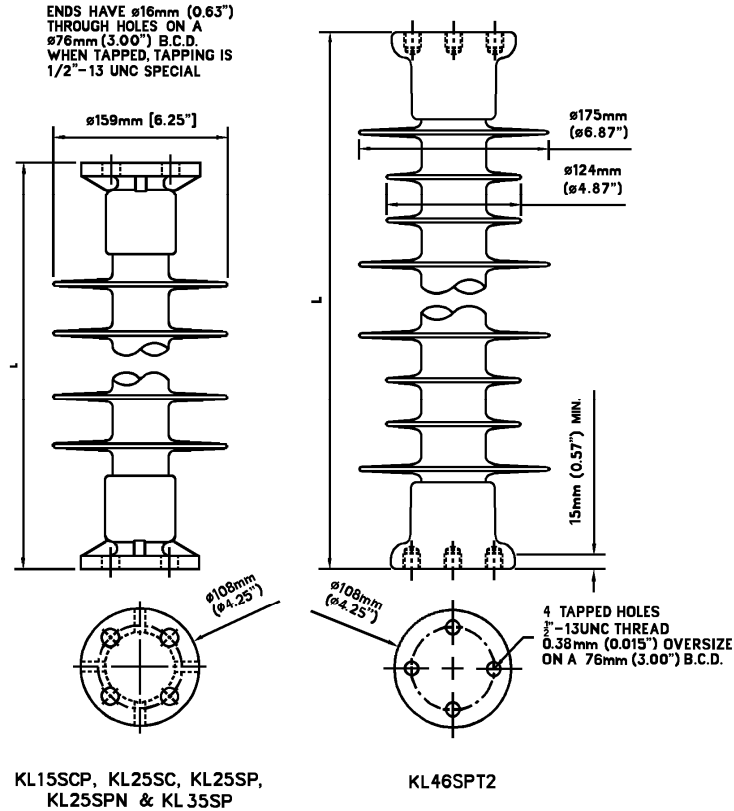

TECHNICAL DATA

SPECIFICATION	UNIT	CATALOGUE NUMBER*							
		KL15SCP	KL25SC	KL25SP	KL25SPN	KL35SP	KL46SPT2	KL46SPP	
Voltage Class	kV	15	25	28	28	35	46	46	
ANSI Technical Reference (TR)	No.	4 & 205	7	208	10	210	214	214	
Section Length (L)	mm (in)	254 (10)	305 (12)	356 (14)	381 (15)	457 (18)	559 (22)	559 (22)	
Dry Arcing Distance	mm (in)	145 (5.7)	184 (7.2)	259 (10.2)	267 (10.5)	339 (13.3)	478 (18.8)	460 (18.1)	
Leakage Distance	mm (in)	275 (10.8)	420 (16.5)	630 (24.8)	657 (25.9)	860 (33.9)	1121 (44.1)	1201 (47.3)	
Impulse Withstand	kV	125	150	180	185	225	275	295	
Positive Critical Impulse Flashover	kV	130	160	190	195	240	310	310	
Low-Frequency Wet Withstand	kV	40	55	75	75	100	140	150	
Radio Influence Voltage (RIV) at 1000 kHz	Test	kV	10	15	22	22	30	30	-
	Max	μV	2.5	2.5	2.5	2.5	2.5	2.5	-
Specified Tensile Load (STL)	kN (lb)	45 (10000)	45 (10000)	45 (10000)	45 (10000)	45 (10000)	45 (10000)	45 (10000)	
Specified Cantilever Load (SCL)	kN (lb)	12.5 (2800)	12.5 (2800)	12.5 (2800)	12.5 (2800)	12.5 (2800)	14.0 (3150)	12.0 (2700)	
Max Design Cantilever Load (MDCL)	kN (lb)	6 (1350)	6 (1350)	6 (1350)	6 (1350)	6 (1350)	7 (1575)	6.0 (1350)	
Number of Sheds	No.	2	3	5	5	6	10	10	
Approx. Weight	kg (lb)	5.0 (11.0)	5.2 (11.5)	5.5 (12.0)	5.9 (12.9)	6.0 (13.4)	9.1 (20.0)	7.0 (15.4)	

* Ordering Information:

1. Above catalogue numbers apply to insulators with through holes on both ends. (Except for KL46SPT2).
2. Add T1 to catalogue numbers for insulators with one end tapped & the other with through holes.
3. Add T2 to catalogue number for insulators with both ends tapped.

END BASES

The standard base fittings are flat round iron bases that are available with bolt circle mounting holes with either through or tapped holes. These bases are compatible with the ceramic Station Post Insulator standard.

The end bases are radially swaged on to the core rod to provide the mechanical performance and reduce the stress concentration. Our proprietary design ensures a watertight seal between the rubber and end fitting. This special silicone rubber to metal fittings sealing process prevents moisture ingress to the core fiberglass rod. For other special base requirements, please contact **KLI**.

Corrosion protection of the end bases is provided by hot-dip galvanizing to CSA G164 or ASTM A153 specifications.

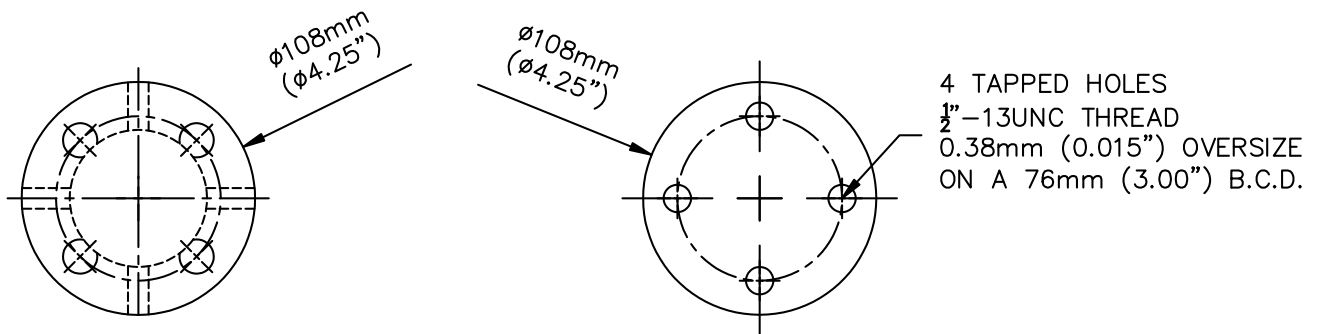

KL15SCP, KL25SC, KL25SP,
KL25SPN & KL35SP

KL46SPT2



K-LINE INSULATORS LIMITED

50 Passmore Avenue, Toronto, Ontario, Canada M1V 4T1

• Tel.: (416) 292-2008 • E-Mail: insulators@k-line.net • Web Page: www.k-line.net