



**K-LINE INSULATORS LIMITED**  
TORONTO, ONTARIO, CANADA

# **Catalogue D-RW**

## **DISTRIBUTION SILICONE INSULATORS**

### ***Railway***

### ***15 kV to 69 kV***



ISO9001  
SAI GLOBAL  
FILE No. 000117

# Distribution Silicone Insulators Railway

Railway insulators perform an important role for the maintaining of railway system reliability. KLI insulators perform well in railway environments where rail dust, carbon particles, rust, and dirt can be present and combine with moisture. KLI insulators use a proprietary rubber formula which helps to give KLI insulators both hydrophobic and self-cleaning properties. The hydrophobic properties help water to form into droplets on insulator housing surfaces rather than forming a continuous film. These water droplets help to avoid losses from leakage currents and to mitigate system outages from power arc flashovers. Rainwater can help with natural self-cleaning when it washes away surface contaminants which often mitigates the need for insulator washing and helps to save on maintenance costs.

**K-LINE INSULATORS LIMITED** silicone rubber Railway Insulators are manufactured and tested in accordance with industry wide standards; CSA and ANSI

**K-LINE INSULATORS LIMITED** is registered to ISO 9001 Quality Systems.

## PERFORMANCE BENEFITS

The performance benefits of **KLI** Distribution Railway Insulators are listed below.

- Improves Reliability (by mitigating interruptions and outages due to vandalism and flashovers in all types of environments)
- Eliminates or Reduces Maintenance (such as washing and trouble calls) and are compatible with existing installation
- Improves Power Quality (less RI and TVI)
- Energy Efficiency (lower losses due to lower leakage currents)
- Service Life (consistent performance over its service life)  
Life Cycle Cost (savings over ceramic insulators)

## APPLICATION

Distribution railway insulators are used on railway infrastructure operating between 15 kV - 69 kV. These insulators directly support the overhead catenary lines from the support structures in electrified systems. They prevent short circuiting and stray currents, ensuring mechanical stability by holding components in place.

## CORE ROD

The core rod of the insulator is made of a high quality, epoxy resin, ECR rod that has been specially formulated for electrical and mechanical applications. Each and every rod is subjected to an electrical test to ensure the integrity of the core rods used in the production of all insulators. KLI's rod is a higher torsion strength rating than standard requirements to ensure safer installation and line operation.

## HOUSING

The housing (includes sheath and sheds) of the insulator is one piece, high temperature vulcanized, injection molded silicone rubber that is chemically bonded to the core rod. This ensures that the interface between the rubber and rod is impenetrable against moisture ingress. **KLI** uses its own proprietary silicone rubber formula in the manufacture of its insulators. The formulation has silicone rubber as the base polymer material with additives to enhance its performance in wet and contaminated environments.

# END FITTINGS

KLI offers different railway end fittings as illustrated below. The end fittings are manufactured from high strength steel or iron and are hot dipped galvanized to resist corrosion. The end fittings are crimped onto the insulator housing and core rod to provide excellent mechanical strength and reliable load-bearing performance. KLI designs use a robust, time-proven sealing design to help prevent moisture ingress which safeguards insulator integrity and helps to provide long-term durability and electrical and mechanical strength.

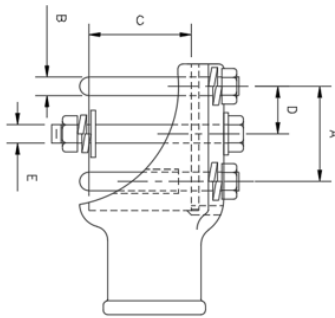

PIPE ADAPTER  
WITH CENTRE BOLT

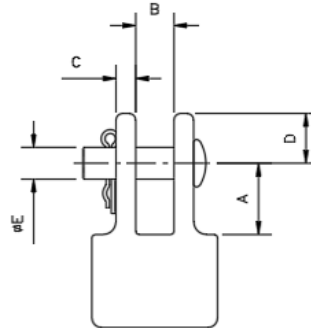

CLEVIS

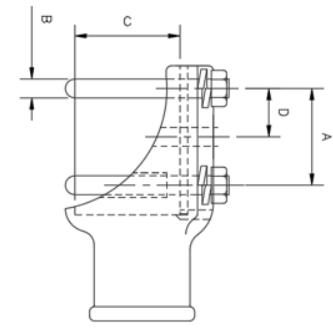

PIPE ADAPTER  
WITHOUT CENTRE BOLT

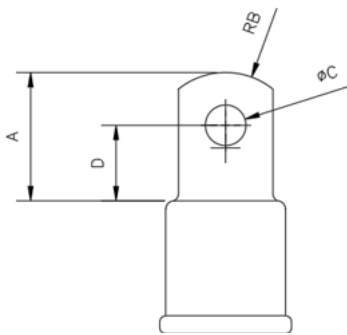

SHORT TONGUE

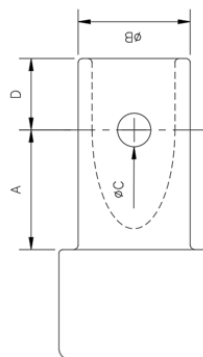

TUBE

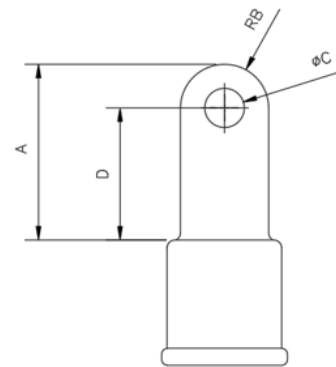

LONG TONGUE

## END FITTING DIMENSIONS

End Fitting	End Fitting Designation	Material	Dimensions (in.)				
			A	B	C	D	E
Clevis	C	Galv. Iron	1.395	0.765	0.39	0.975	0.625
Pipe Adapter (Without Center Bolt)	P	Galv. Iron	2.56	0.5	2.76	-	-
Pipe Adapter (With Center Bolt)		Galv. Iron	2.56	0.5	2.76	1.28	0.5
Short Tongue	T	Galv. Iron	2.676	1.575	0.847	1.57	-
Long Tongue	T	Galv. Iron	3.89	0.97	0.866	2.92	-
Tube	TU	Galv. Iron	1.975	1.86	0.555	1.18	-



### K-LINE INSULATORS LIMITED

50 Passmore Avenue, Toronto, Ontario, Canada M1V 4T1

• Tel.: (416) 292-2008 • E-Mail: [insulators@k-line.net](mailto:insulators@k-line.net) • Web Page: [www.k-line.net](http://www.k-line.net)

# DISTRIBUTION RAILWAY INSULATORS - 15 kV - 69 kV

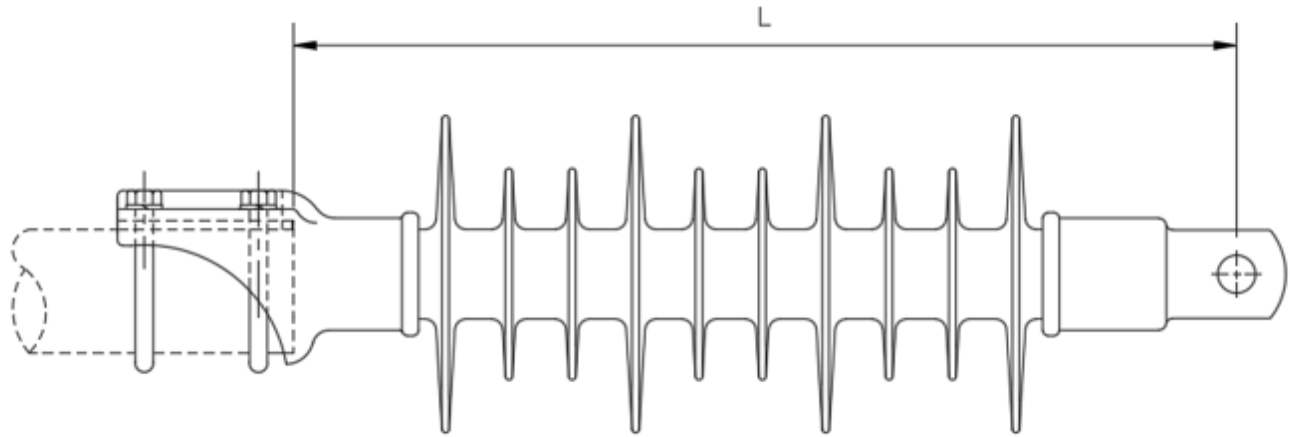

## TECHNICAL DATA

SPECIFICATIONS	UNIT	CATALOGUE NUMBER					
		KL15RWPT01	KL28RWCT1	KL35RWPT01	KL46RWPT01	KL69RWPT01	
Voltage Class	kV	15	28	35	46	69	
Nominal Voltage Rating	kV	11	20	25	38	69	
Section Length "L"	mm (in)	246 (9.8)	310 (12.2)	424 (16.7)	500 (19.7)	537 (21.1)	
Dry Arcing Disatnce	mm (in)	130 (5.1)	190 (7.5)	264 (10.4)	339 (13.3)	445 (17.5)	
Leakage Distance	mm (in)	259 (10.2)	420 (16.5)	657 (25.9)	860 (33.9)	1171 (46.1)	
Positive Critical Impulse Flashover	kV	125	160	195	240	300	
Low Frequeuncy Flashover	Dry	kV	70	95	120	145	190
	Wet	kV	40	65	85	115	150
Approx. Weight	kg (lbs.)	5.9 (13.1)	3.3 (7.4)	7.3 (16.2)	7.7 (17.0)	8.4 (18.5)	
Standard Packaging	-	2	3	2	2	2	

## ORDERING INFORMATION

For ordering, the catalog number of the specific insulator is formulated as shown below:

